

A
SIZE

PROJECTIONS



TOLERANCES UNLESS OTHERWISE SPECIFIED:

PLACES	INCHES	NOTES:
.XX	± .030	ACCEPTABLE BURR ± 10% OF MATERIAL THICKNESS
.XXX	± .015	ALL TOLERANCES ARE NON-CUMULATIVE
.XXXX	± .005	ALL DIMENSIONS APPLY TO PART BEFORE ANY FINISH IS APPLIED
ANGLE	± 3°	

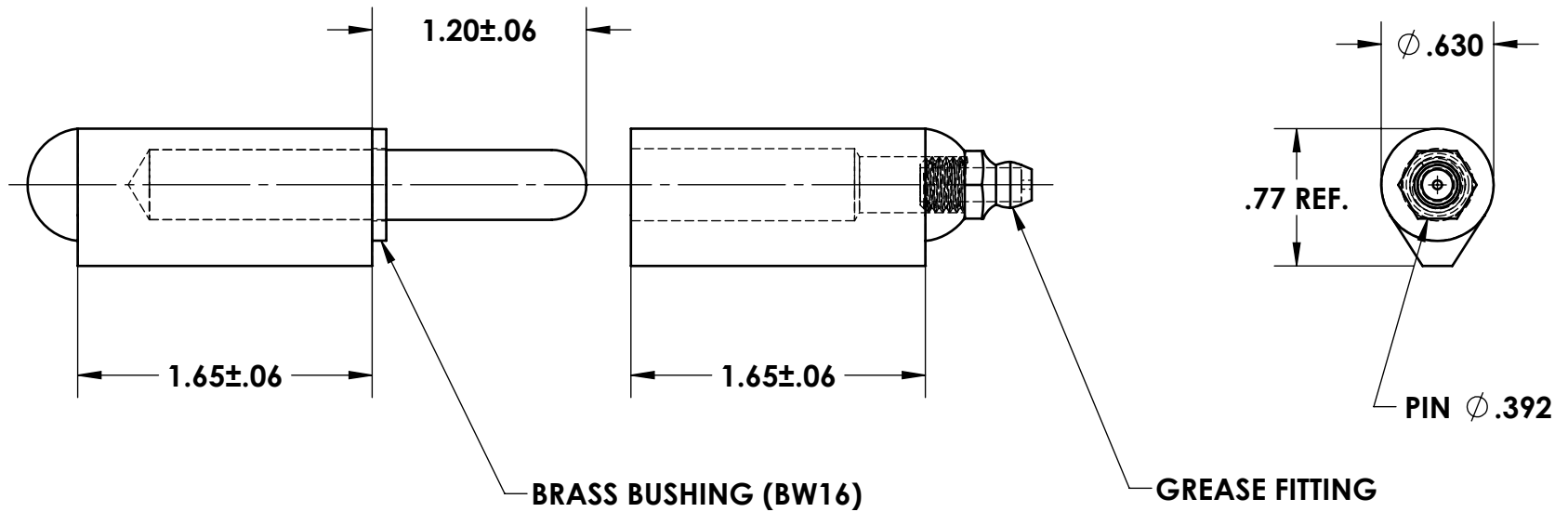

NOTES:

1. FINISH: 00- NO FINISH
2. OVERALL ASSEM. LENGTH: APPROX. 4.22 INCHES

D	PIN DIA.	08/06/2019	JG	DWG #: PSWM040FP-GF	SCALE	1:1	CODE IDENT. #
C	CONVERTED	08/15/2017	JG		DATE	03/18/1998	03007
B	PIN TOLERANCE	10/10/2013	JG	MATERIAL: PS	 GUDEN INDUSTRIAL HARDWARE MADE EASY 99 RAYNOR AVE. RONKONKOMA, N.Y. 11779 1-800-3-HINGES		
A	1.65 WAS 1.63	02/23/2011	JG	FINISH: SEE NOTE			
REV.	DESCRIPTION	DATE	APPD	DR. BY: RAG			
REVISIONS				FAX: 1-631-737-2933 EMAIL: info@guden.com WEB: www.guden.com			