

**A**  
SIZE

PROJECTIONS

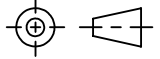

TOLERANCES UNLESS OTHERWISE SPECIFIED:

PLACES	INCHES	NOTES:
.XX	± .030	ACCEPTABLE BURR ± 10% OF MATERIAL THICKNESS
.XXX	± .015	ALL TOLERANCES ARE NON-CUMULATIVE
.XXXX	± .005	ALL DIMENSIONS APPLY TO PART BEFORE ANY FINISH IS APPLIED
ANGLE	± 3°	

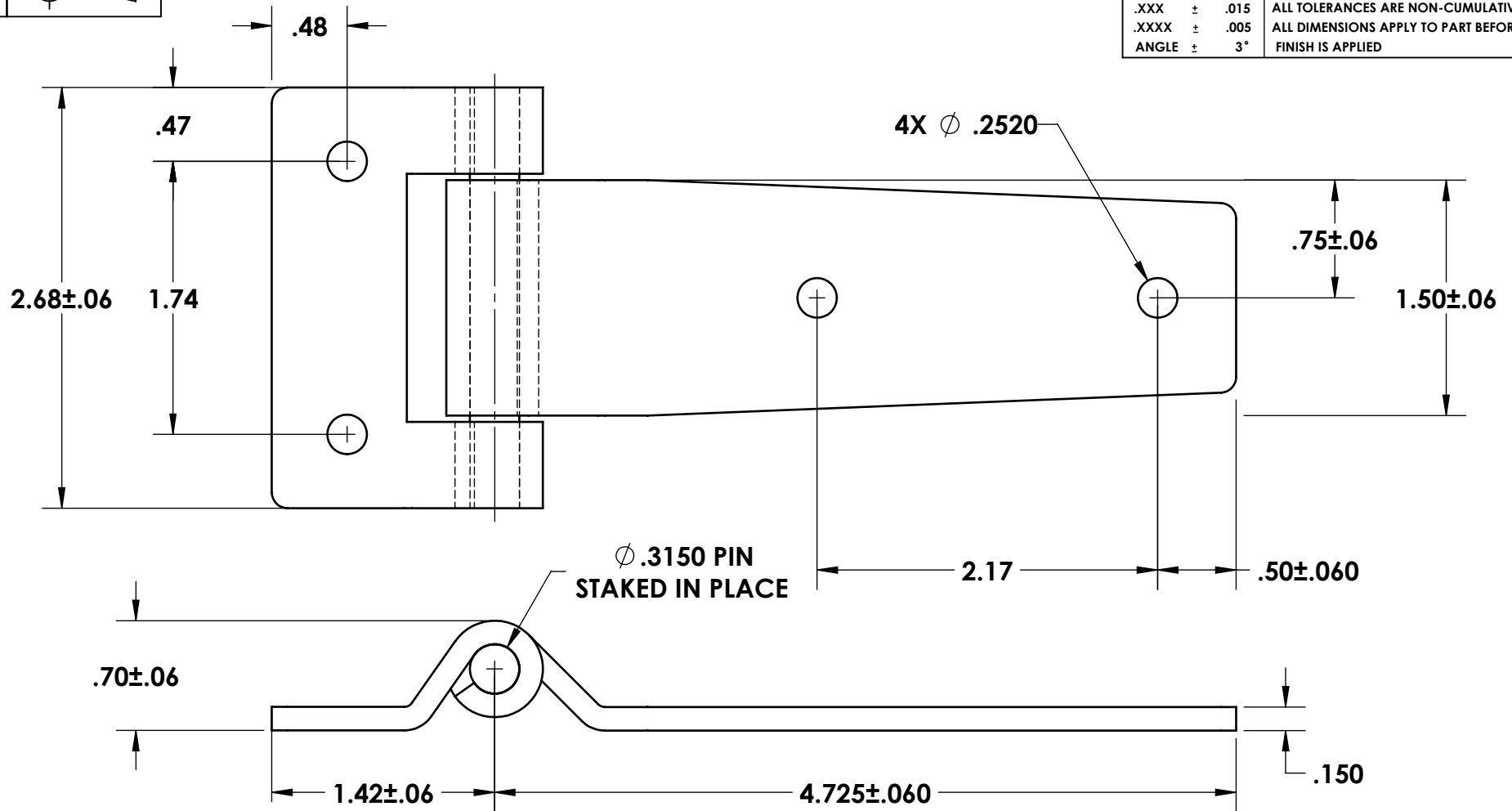

## NOTES:

- FINISH: 12- POLISH - TOPSIDE & KNUCKLE ALL AROUND
- HINGE ASSEMBLED WITH NYLON FLANGE BUSHINGS

REV.	DESCRIPTION	DATE	APPD
D	ADDED BUSHING NOTE	06/19/2020	JG
C	CONVERTED	09/28/2017	JG
B	VARIOUS DIM CHANGES	03/01/2016	JG

REVISIONS

DWG #:

**STRP0472RVA1**MATERIAL:  
304-ST3FINISH:  
SEE NOTE

DR. BY: RAG

CK. BY: CD

FAX: 1-631-737-2933

EMAIL: info@guden.com

WEB: www.guden.com

SCALE

1:1

CODE IDENT. #

DATE

09/26/2002

03007

**GUDEN**

INDUSTRIAL HARDWARE MADE EASY

99 RAYNOR AVE.

RONKONKOMA, N.Y. 11779

1-800-3-HINGES