

**A**  
SIZE

PROJECTIONS

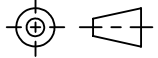

TOLERANCES UNLESS OTHERWISE SPECIFIED:

PLACES	INCHES	NOTES:
.XX	± .030	ACCEPTABLE BURR ± 10% OF MATERIAL THICKNESS
.XXX	± .015	ALL TOLERANCES ARE NON-CUMULATIVE
.XXXX	± .005	ALL DIMENSIONS APPLY TO PART BEFORE ANY FINISH IS APPLIED
ANGLE	± 3°	

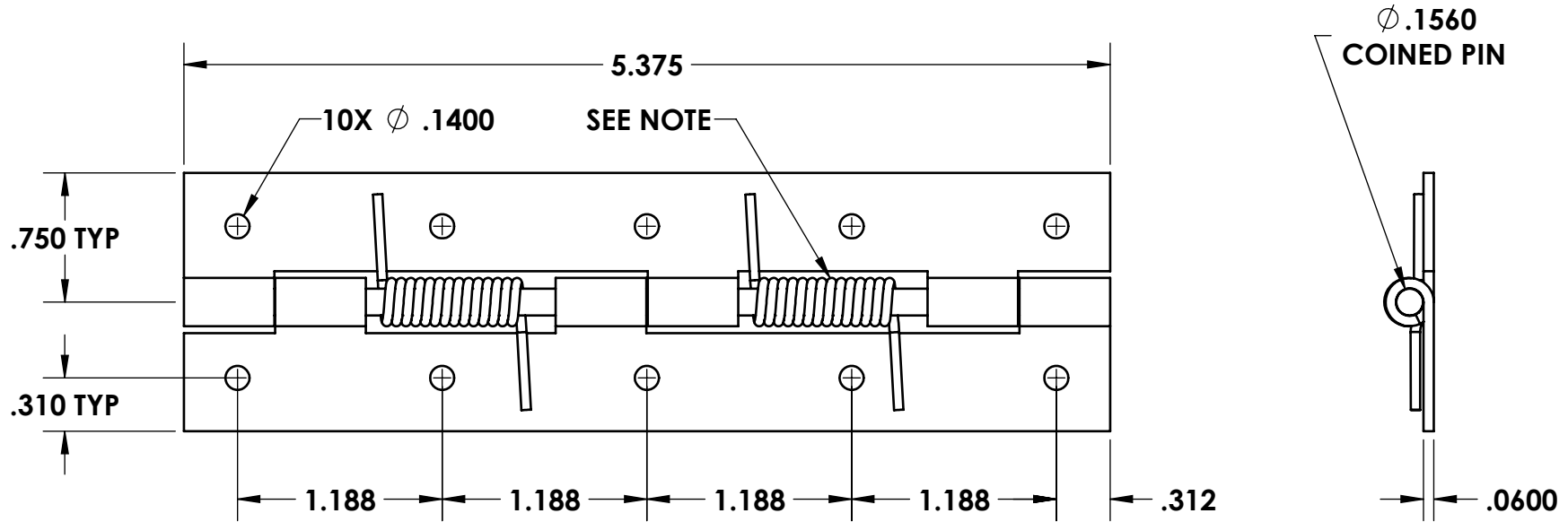

**NOTES:**

1. FINISH: 361 - BRIGHT ANNEALED
2. SPRING: LOADED TO OPEN, (2) PLACES, .055 WIRE DIA., .63 LEGS
3. KNUCKLES: .53 REF.

REVISIONS				DWG #:		SCALE	1:1	CODE IDENT. #
				<b>WHSTS1126</b>		DATE	10/05/2005	03007
C	COINED PIN WAS SPUN	10/14/2021	JG	MATERIAL:	FINISH:	 99 RAYNOR AVE. RONKONKOMA, N.Y. 11779 1-800-3-HINGES		
B	SPRING NOTE	10/16/2017	JG	304-ST5	SEE NOTE			
A	CONVERTED, FINISH	09/21/2017	JG	DR. BY: RAG	CK. BY: CD			
REV.	DESCRIPTION	DATE	APPD	FAX: 1-631-737-2933 EMAIL: info@guden.com WEB: www.guden.com				