

A
SIZE

PROJECTIONS

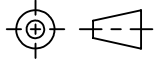

TOLERANCES UNLESS OTHERWISE SPECIFIED:

PLACES	INCHES	NOTES:
.XX	± .030	ACCEPTABLE BURR ± 10% OF MATERIAL THICKNESS
.XXX	± .015	ALL TOLERANCES ARE NON-CUMULATIVE
.XXXX	± .005	ALL DIMENSIONS APPLY TO PART BEFORE ANY FINISH IS APPLIED
ANGLE	± 3°	

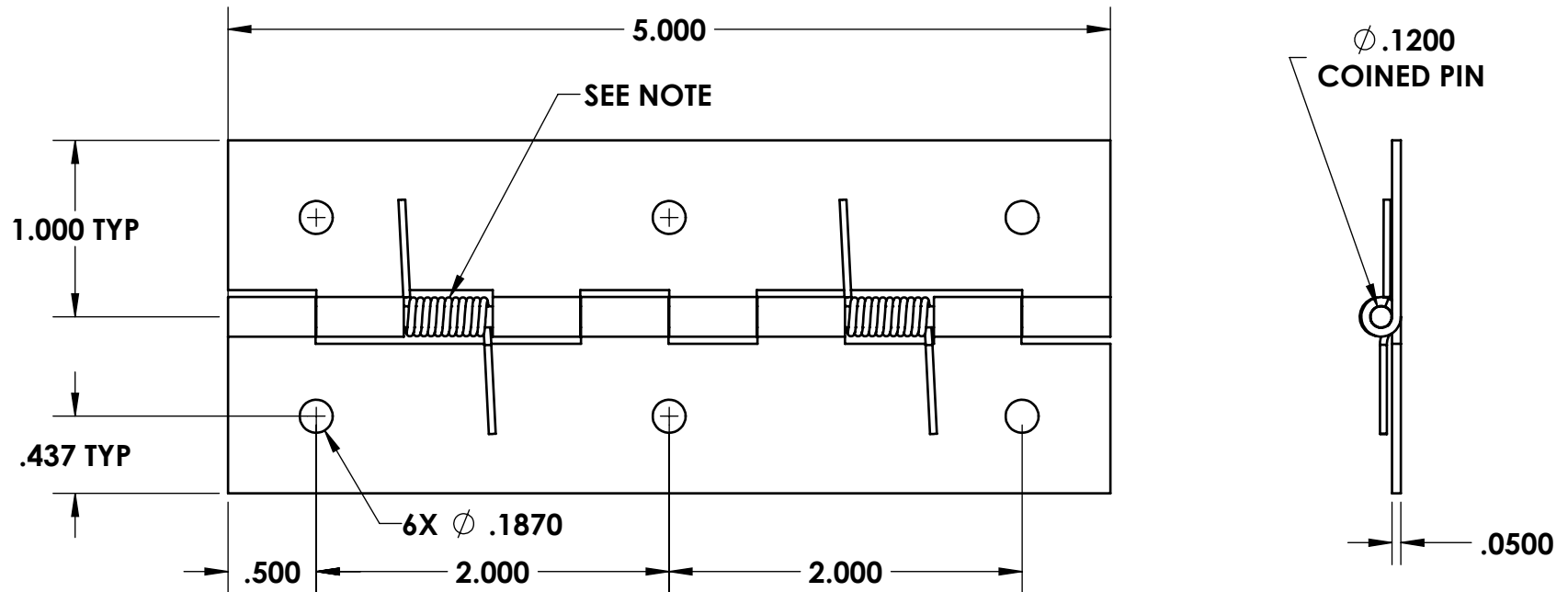

NOTES:

- FINISH: 105- BARREL ZINC AND CLEAR TRIVALENT CHROMATE (PIN MAY BE NICKEL PLATED)
- SPRING: LOADED TO OPEN, (2) PLACE, .039 STS WIRE DIA., .62 LEGS
- KNUCKLES: .50 REF.

REV.	DESCRIPTION	DATE	APPD	DWG #:	SCALE	1:1	CODE IDENT. #
D	CHANGED FINISH	09/08/2021	JG	PS1122-02	DATE	05/09/2001	03007
C	CONVERTED, SPRING NOTE	01/09/2018	JG		MATERIAL:	PS	FINISH:
B	CHANGED SPRING	12/17/2013	JG	DR. BY:	RAG	CK. BY:	CD
A	CHANGED FINISH	12/28/2012	JG	FAX: 1-631-737-2933		 99 RAYNOR AVE. RONKONKOMA, N.Y. 11779 1-800-3-HINGES	
REVISIONS				EMAIL: info@guden.com			
				WEB: www.guden.com			