

A
SIZE

PROJECTIONS

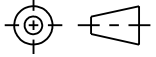

TOLERANCES UNLESS OTHERWISE SPECIFIED:

PLACES	INCHES	NOTES:
.XX	± .030	ACCEPTABLE BURR ± 10% OF MATERIAL THICKNESS
.XXX	± .015	ALL TOLERANCES ARE NON-CUMULATIVE
.XXXX	± .005	ALL DIMENSIONS APPLY TO PART BEFORE ANY FINISH IS APPLIED
ANGLE	± 3°	

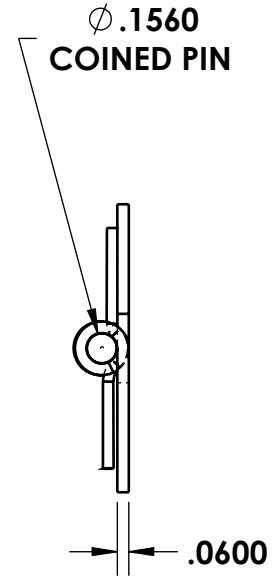
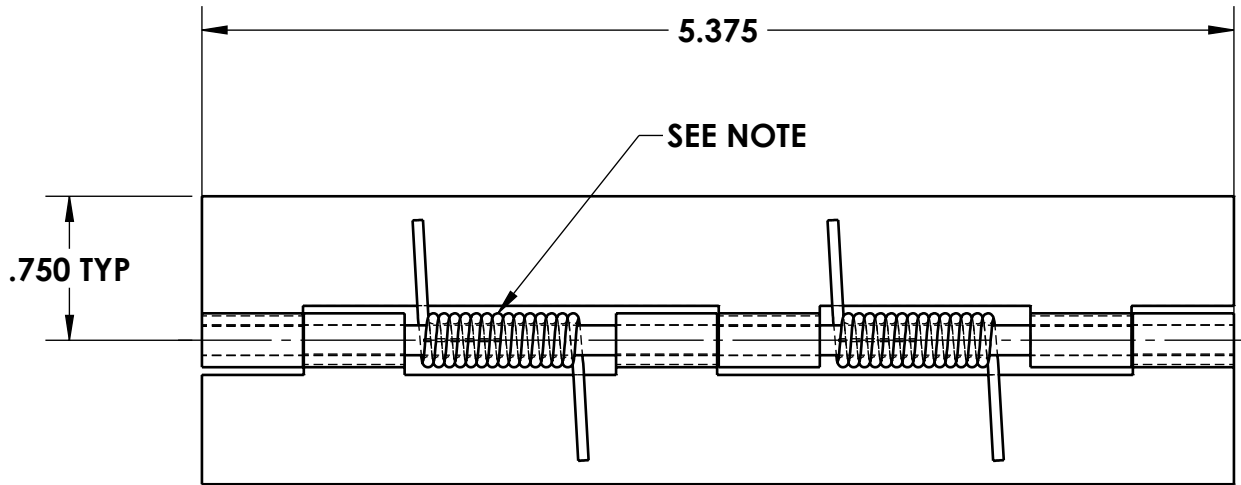

NOTES:

1. FINISH: 00- NO FINISH
2. SPRING: LOADED TO OPEN, (2) PLACES, .055 STS WIRE DIA., .65 LEGS
3. KNUCKLES: .53 REF.

REV. DESCRIPTION DATE APPD				DWG #:		SCALE	1:1	CODE IDENT. #
				NHPS1126		DATE	10/05/2005	03007
B	COINED WAS SPUN	07/26/2023	JG	MATERIAL:	FINISH:	 99 RAYNOR AVE. RONKONKOMA, N.Y. 11779 1-800-3-HINGES		
A	SPRING NOTE	01/11/2018	JG	PS	SEE NOTE			
REV.	DESCRIPTION	DATE	APPD	DR. BY: RAG	CK. BY: CD			
REVISIONS				FAX: 1-631-737-2933 EMAIL: info@guden.com WEB: www.guden.com				