

A
SIZE

PROJECTIONS

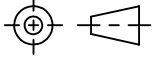

TOLERANCES UNLESS OTHERWISE SPECIFIED:

PLACES	INCHES	NOTES:
.XX	± .030	ACCEPTABLE BURR ± 10% OF MATERIAL THICKNESS
.XXX	± .015	ALL TOLERANCES ARE NON-CUMULATIVE
.XXXX	± .005	ALL DIMENSIONS APPLY TO PART BEFORE ANY FINISH IS APPLIED
ANGLE	± 3°	

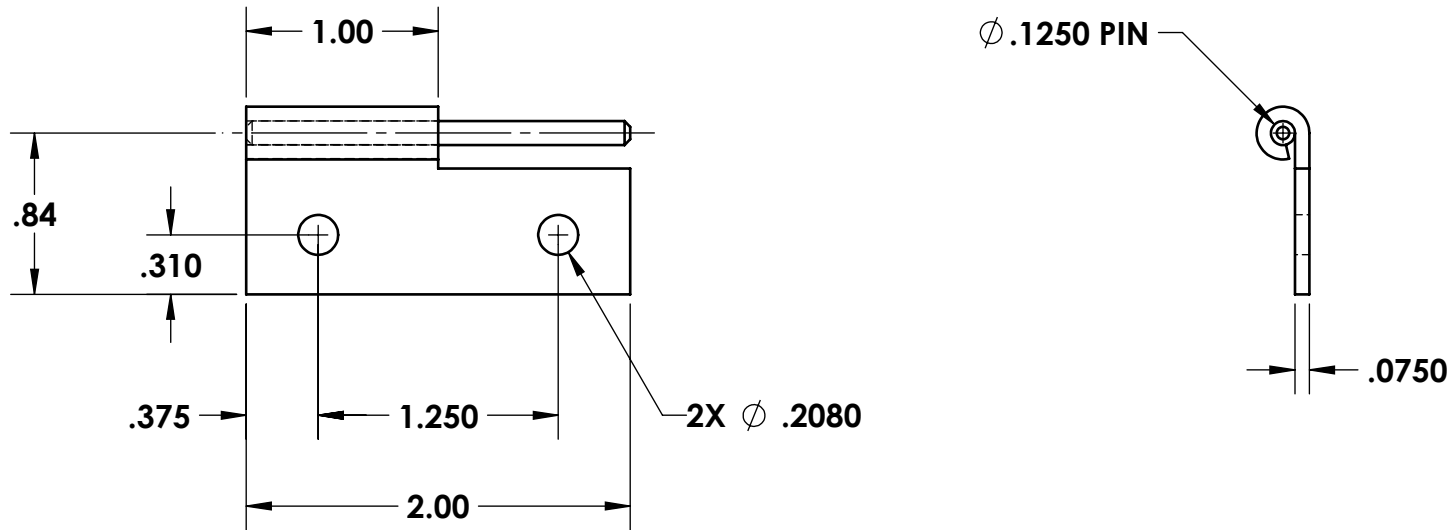

NOTES:
1. FINISH: 00- NO FINISH

				DWG #:		SCALE	1:1	CODE IDENT. #
				WHPS80220RM		DATE	02/03/2003	03007
B	CHANGED MATERIAL THICKNESS	06/04/2019	JG	MATERIAL:	FINISH:	 GUDEN INDUSTRIAL HARDWARE MADE EASY 99 RAYNOR AVE. RONKONKOMA, N.Y. 11779 1-800-3-HINGES		
A	CHANGED MATERIAL THICKNESS	10/14/2003	CD	PS	SEE NOTE			
REV.	DESCRIPTION	DATE	APPD	DR. BY: RAG	CK. BY: CD			
REVISIONS				FAX: 1-631-737-2933 EMAIL: info@guden.com WEB: www.guden.com				