

A
SIZE

PROJECTIONS



TOLERANCES UNLESS OTHERWISE SPECIFIED:

PLACES	INCH
.XX	± .030
.XXX	± .015
.XXXX	± .005
ANGLE	± 3°

NOTE:
ACCEPTABLE BURR ± 10% OF MATERIAL THICKNESS
ALL TOLERANCES ARE NON-CUMULATIVE
ALL DIMENSIONS APPLY TO PART BEFORE ANY FINISH IS APPLIED

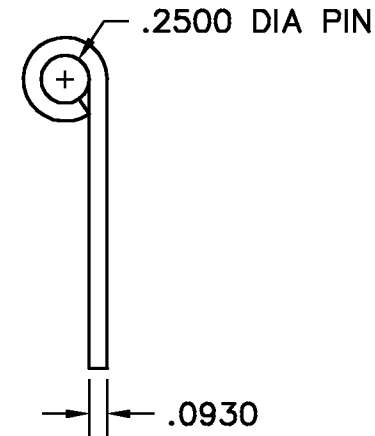
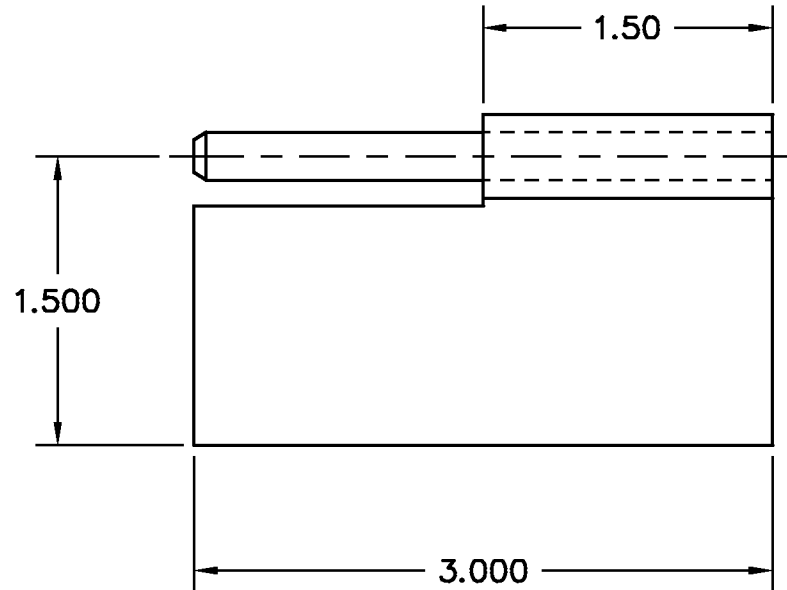

NOTES:
1. FINISH: 00- NO FINISH

DWG		SCALE	1:1	CODE IDENT. #
NHSS80630LM		DATE	12/30/98	03007
MATERIAL	FINISH			
STS	SEE NOTE			
DR. BY RAG	CK. BY CD	99 RAYNOR AVE. RONKONKOMA, N.Y. 11779 1-800-3-HINGES		
FAX: 1-631-737-2933 EMAIL: info@guden.com WEB: www.guden.com				

E	MATERIAL THICKNESS	01/26/09	CD
D	MATERIAL THICKNESS	12/22/08	CD
C	REDRAWN	12/30/98	CD
LTR	DESCRIPTION	DATE	APPD
REVISION			