

A
SIZE

PROJECTIONS

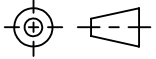

TOLERANCES UNLESS OTHERWISE SPECIFIED:

PLACES	INCHES	NOTES:
.XX	± .030	ACCEPTABLE BURR ± 10% OF MATERIAL THICKNESS
.XXX	± .015	ALL TOLERANCES ARE NON-CUMULATIVE
.XXXX	± .005	ALL DIMENSIONS APPLY TO PART BEFORE ANY FINISH IS APPLIED
ANGLE	± 3°	

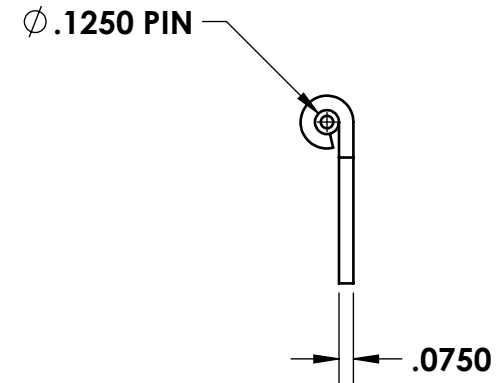
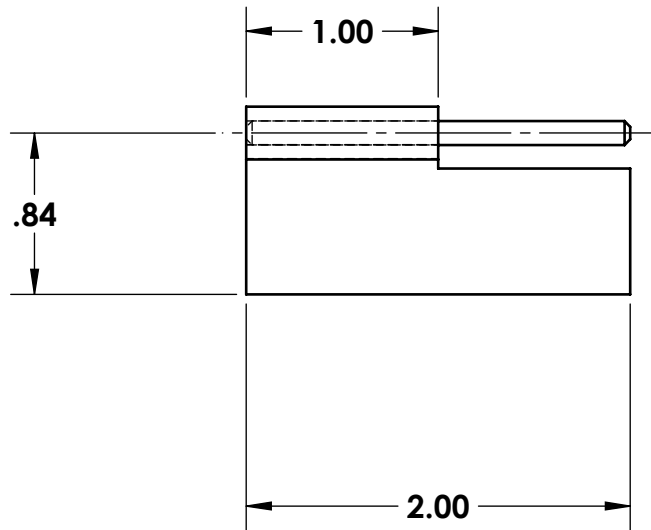

NOTES:
1. FINISH: 00- NO FINISH

REVISIONS				DWG #:	SCALE	1:1	CODE IDENT. #
E	CONVERTED	06/04/2019	JG	NHPS80220RM	DATE	11/04/1998	03007
D	CHANGED PIN	12/10/2007	CD		MATERIAL:	FINISH:	
C	CHANGED MATERIAL THICKNESS	10/14/2003	CD	PS	SEE NOTE		 GUDEN INDUSTRIAL HARDWARE MADE EASY 99 RAYNOR AVE. RONKONKOMA, N.Y. 11779 1-800-3-HINGES
REV.	DESCRIPTION	DATE	APPD	DR. BY: RAG	CK. BY: CD		
				FAX: 1-631-737-2933 EMAIL: info@guden.com WEB: www.guden.com			