

A
SIZE

PROJECTIONS

TOLERANCES UNLESS OTHERWISE SPECIFIED:

PLACES	INCHES	NOTES:
.XX	± .030	ACCEPTABLE BURR ± 10% OF MATERIAL THICKNESS
.XXX	± .015	ALL TOLERANCES ARE NON-CUMULATIVE
.XXXX	± .005	ALL DIMENSIONS APPLY TO PART BEFORE ANY FINISH IS APPLIED
ANGLE	± 3°	

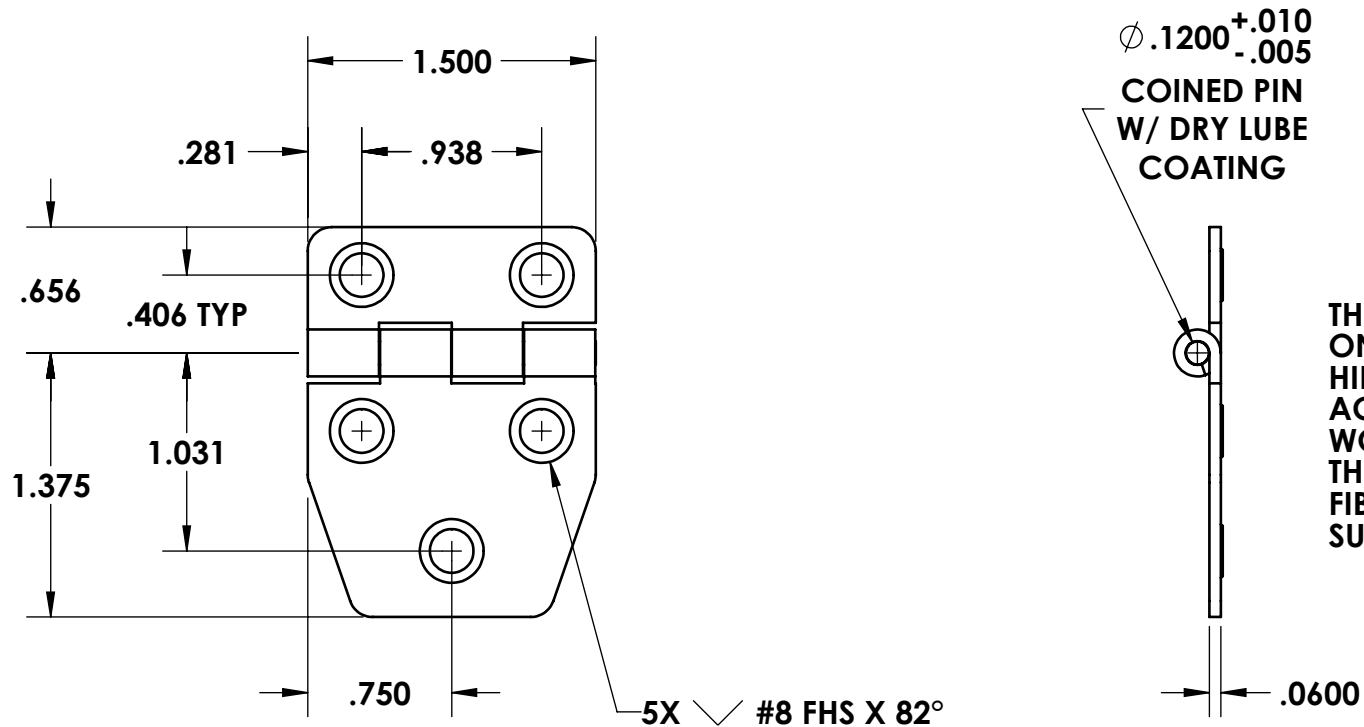

THE SLIGHTLY RAISED AREA ON THE BACK OF THESE HINGES MAKE THEM ACCEPTABLE FOR USE ON WOOD ONLY. THEY WILL NOT LAY FLAT ON FIBERGLASS OR METAL SURFACES.

NOTES:
1. FINISH: 21- ELECTRO POLISH

REV. DESCRIPTION DATE APPD				DWG #:	SCALE	1:1	CODE IDENT. #
C	ADDED PIN LUBE, COINED	01/15/2018	JG	SP0999	DATE	06/20/2001	03007
B	CONVERTED, VARIOUS CHANGES	05/08/2017	JG		MATERIAL: 304-STS	FINISH: SEE NOTE	 GUDEN INDUSTRIAL HARDWARE MADE EASY 99 RAYNOR AVE. RONKONKOMA, N.Y. 11779 1-800-3-HINGES
A	ADDED "WOOD ONLY" NOTE	07/24/2001	CD	DR. BY: RAG	CK. BY: CD		
REV.	DESCRIPTION	DATE	APPD	FAX: 1-631-737-2933 EMAIL: info@guden.com WEB: www.guden.com			
REVISIONS							