

A
SIZE

PROJECTIONS

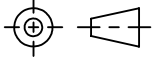

TOLERANCES UNLESS OTHERWISE SPECIFIED:

PLACES	INCHES	NOTES:
.XX	± .030	ACCEPTABLE BURR ± 10% OF MATERIAL THICKNESS
.XXX	± .015	ALL TOLERANCES ARE NON-CUMULATIVE
.XXXX	± .005	ALL DIMENSIONS APPLY TO PART BEFORE ANY FINISH IS APPLIED
ANGLE	± 3°	

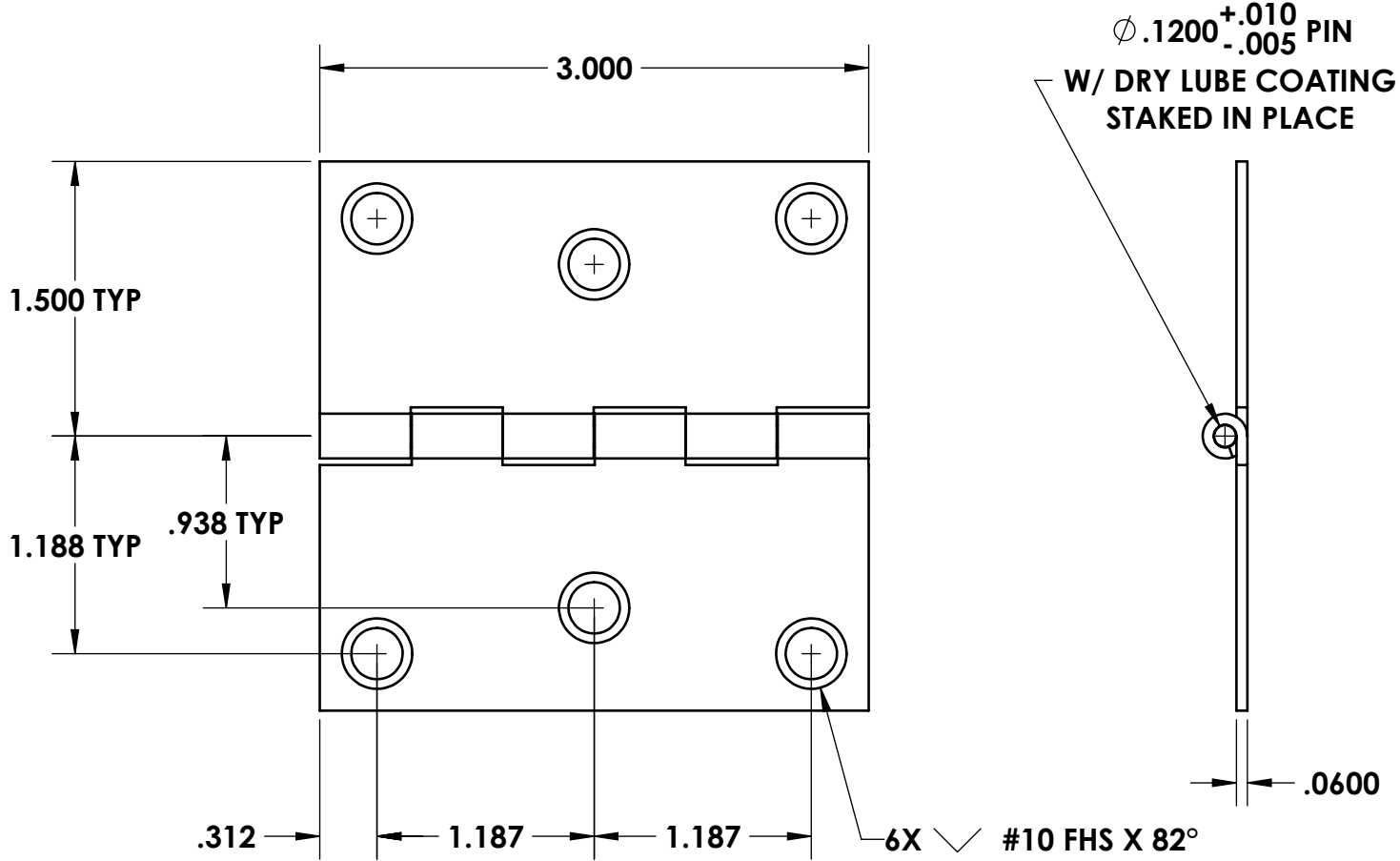

NOTES:
1. FINISH: 21- ELECTRO POLISH

REV.	DESCRIPTION	DATE	APPD
C	ADDED PIN LUBE	01/08/2018	JG
B	CONVERTED, VARIOUS CHANGES	05/08/2017	JG
A	CORRECTED HOLES	06/04/2015	JG
REVISIONS			

DWG #:		SCALE	1:1	CODE IDENT. #
SP0994		DATE	06/20/2001	03007
MATERIAL:	FINISH:	GUDEN INDUSTRIAL HARDWARE MADE EASY 99 RAYNOR AVE. RONKONKOMA, N.Y. 11779 1-800-3-HINGES		
304-ST5	SEE NOTE			
DR. BY: RAG	CK. BY: CD			
FAX: 1-631-737-2933				
EMAIL: info@guden.com				
WEB: www.guden.com				