

A
SIZE

PROJECTIONS

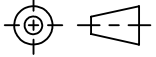

TOLERANCES UNLESS OTHERWISE SPECIFIED:

PLACES	INCHES	NOTES:
.XX	± .030	ACCEPTABLE BURR ± 10% OF MATERIAL THICKNESS
.XXX	± .015	ALL TOLERANCES ARE NON-CUMULATIVE
.XXXX	± .005	ALL DIMENSIONS APPLY TO PART BEFORE ANY FINISH IS APPLIED
ANGLE	± 3°	

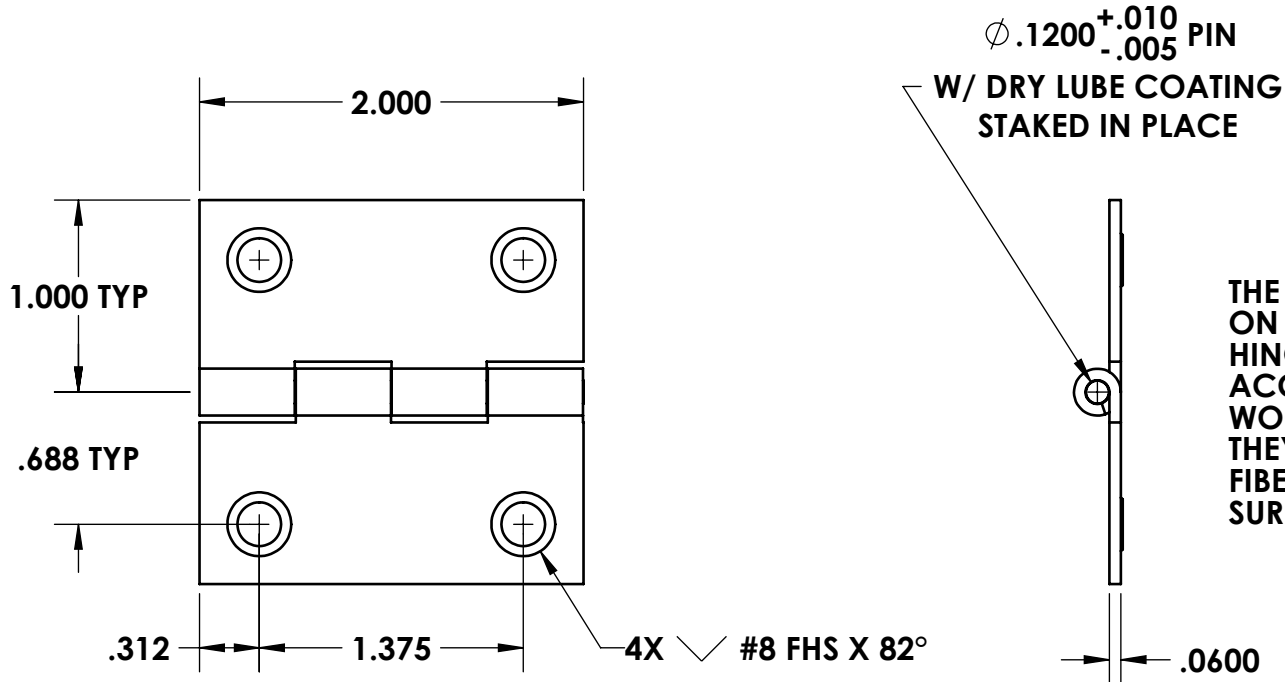

THE SLIGHTLY RAISED AREA ON THE BACK OF THESE HINGES MAKE THEM ACCEPTABLE FOR USE ON WOOD ONLY. THEY WILL NOT LAY FLAT ON FIBERGLASS OR METAL SURFACES.

NOTES:
1. FINISH: 21- ELECTRO POLISH

REV. DESCRIPTION DATE APPD				DWG #:		SCALE	1:1	CODE IDENT. #
C	ADDED PIN LUBE	01/08/2018	JG	SP0992		DATE	06/20/2001	03007
B	CONVERTED, VARIOUS CHANGES	05/05/2017	JG					
A	ADDED "WOOD ONLY" NOTE	07/24/2001	CD	MATERIAL: 304-STS	FINISH: SEE NOTE	 GUDEN INDUSTRIAL HARDWARE MADE EASY 99 RAYNOR AVE. RONKONKOMA, N.Y. 11779 1-800-3-HINGES		
REV.	DESCRIPTION	DATE	APPD	DR. BY: RAG	CK. BY: CD			
REVISIONS				FAX: 1-631-737-2933 EMAIL: info@guden.com WEB: www.guden.com				