

A
SIZE

PROJECTIONS

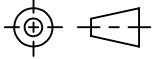

TOLERANCES UNLESS OTHERWISE SPECIFIED:

PLACES	INCHES	NOTES:
.XX	± .030	ACCEPTABLE BURR ± 10% OF MATERIAL THICKNESS
.XXX	± .015	ALL TOLERANCES ARE NON-CUMULATIVE
.XXXX	± .005	ALL DIMENSIONS APPLY TO PART BEFORE ANY FINISH IS APPLIED
ANGLE	± 3°	

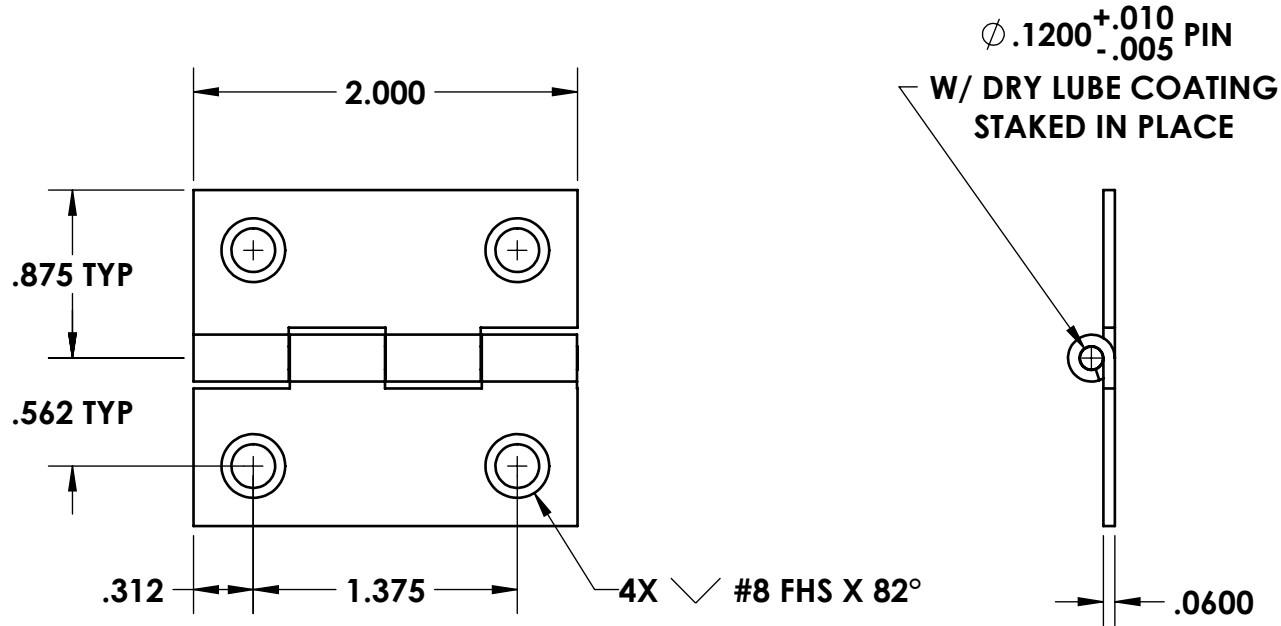

NOTES:
1. FINISH: 21- ELECTRO POLISH

REV. DESCRIPTION DATE APPD				DWG #:		SCALE	1:1	CODE IDENT. #
				SP0991		DATE	06/20/2001	03007
B	ADDED PIN LUBE	01/08/2018	JG	MATERIAL:	FINISH:	 99 RAYNOR AVE. RONKONKOMA, N.Y. 11779 1-800-3-HINGES		
A	CONVERTED, VARIOUS CHANGES	05/05/2017	JG	304-ST5	SEE NOTE			
				DR. BY: RAG	CK. BY: CD			
REVISIONS				FAX: 1-631-737-2933				
				EMAIL: info@guden.com				
				WEB: www.guden.com				