

**A**  
SIZE

PROJECTIONS

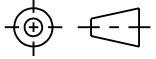

TOLERANCES UNLESS OTHERWISE SPECIFIED:

PLACES	INCHES	NOTES:
.XX	± .030	ACCEPTABLE BURR ± 10% OF MATERIAL THICKNESS
.XXX	± .015	ALL TOLERANCES ARE NON-CUMULATIVE
.XXXX	± .005	ALL DIMENSIONS APPLY TO PART BEFORE ANY FINISH IS APPLIED
ANGLE	± 3°	

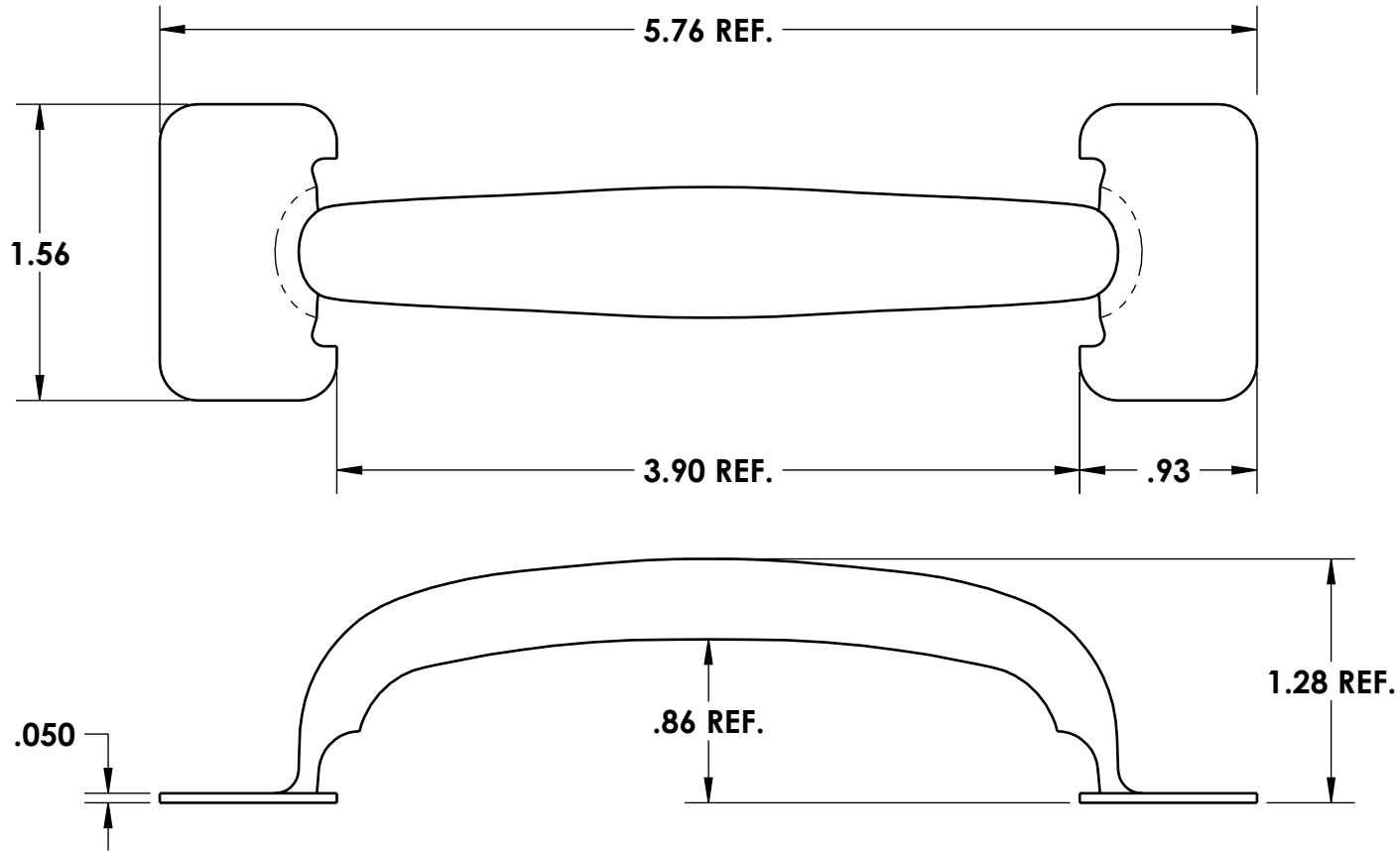

NOTES:  
1. FINISH: 00- NO FINISH

REVISIONS				DWG #:	SCALE	1:1	CODE IDENT. #
C	3.90 REF., .86 REF. WAS 3.90, .86	02/01/2023	JG	<b>NHPS48220</b>	DATE	04/23/1996	03007
B	VARIOUS CHANGES	04/20/2022	JG		MATERIAL:	PS	FINISH:
A	CONVERTED	03/26/2018	JG	DR. BY:	RAG	CK. BY:	CD
REV.	DESCRIPTION	DATE	APPD	FAX: 1-631-737-2933		 99 RAYNOR AVE. RONKONKOMA, N.Y. 11779 1-800-3-HINGES	
				EMAIL: info@guden.com			
				WEB: www.guden.com			