

A
SIZE

PROJECTIONS



TOLERANCES UNLESS OTHERWISE SPECIFIED:

PLACES	INCH
.XX	± .030
.XXX	± .015
.XXXX	± .005
ANGLE	3°

NOTE:
ACCEPTABLE BURR ± 10% OF MATERIAL THICKNESS
ALL TOLERANCES ARE NON-CUMULATIVE
ALL DIMENSIONS APPLY TO PART BEFORE ANY FINISH IS APPLIED

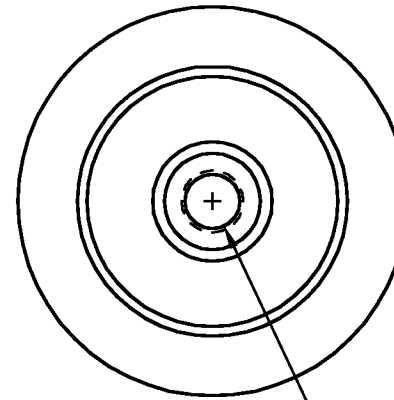
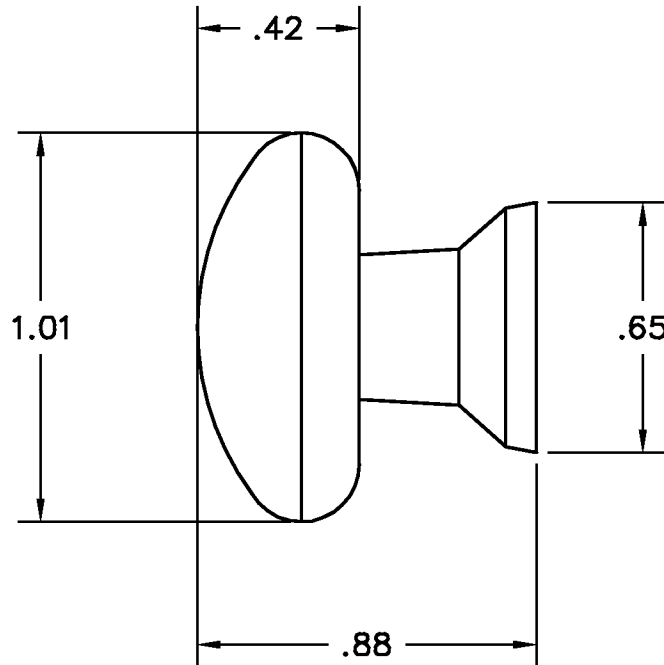

.140 DIA HOLE
TAPPED 8-32 UNC
.44 DEEP

NOTES:

1. FINISH: 41- POLISHED CHROME
2. MATERIAL: ZINC DIE CAST

DWG		SCALE	2:1	CODE IDENT. #
G105-26		DATE	12/11/01	03007
MATERIAL	FINISH			
SEE NOTE	SEE NOTE			
DR. BY RAG	CK. BY CD	99 RAYNOR AVE. RONKONKOMA, N.Y. 11779 1-800-3-HINGES		
FAX: 1-631-737-2933 EMAIL: info@guden.com WEB: www.guden.com				

LTR	DESCRIPTION	DATE	APPD
	REVISION		