

A
SIZE

PROJECTIONS

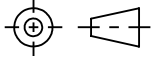

TOLERANCES UNLESS OTHERWISE SPECIFIED:

PLACES	INCHES	NOTES:
.XX	± .030	ACCEPTABLE BURR ± 10% OF MATERIAL THICKNESS
.XXX	± .015	ALL TOLERANCES ARE NON-CUMULATIVE
.XXXX	± .005	ALL DIMENSIONS APPLY TO PART BEFORE ANY
ANGLE	± 3°	FINISH IS APPLIED

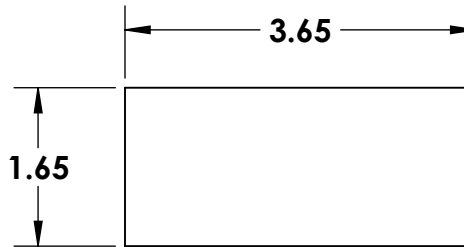
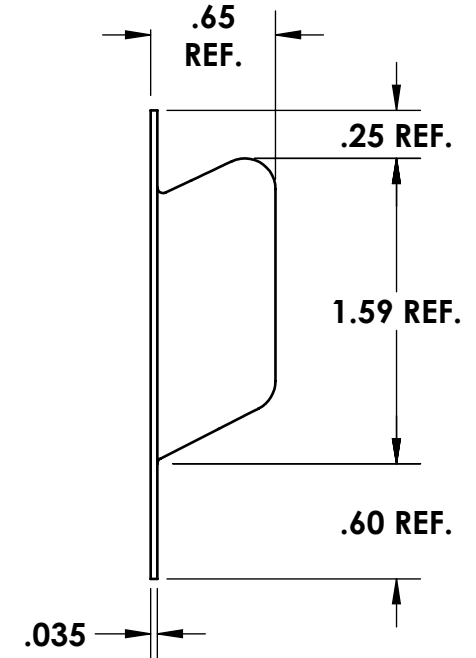
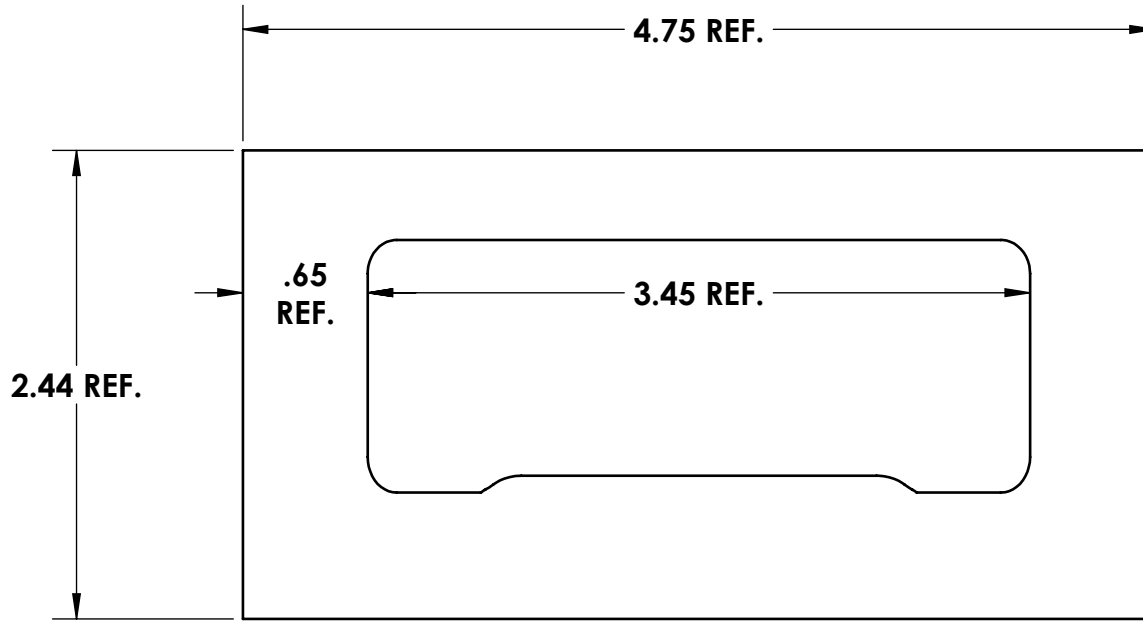

MOUNTING TEMPLATE

NOTES:
1. FINISH: 29- BRUSHED TOPSIDE ONLY

D	VARIOUS CHANGES	10/04/2023	JG	DWG #: 1898-32D	SCALE	1:1	CODE IDENT. #
C	CONVERTED	03/30/2018	JG		DATE	11/30/1994	03007
B	VARIOUS CHANGES	03/05/2001	CD	MATERIAL: 304-ST	FINISH: SEE NOTE		
A	VARIOUS DIM CHANGES	04/07/1995	RK	DR. BY: RAG	CK. BY: RK		
REV.	DESCRIPTION	DATE	APPD	FAX: 1-631-737-2933 EMAIL: info@guden.com WEB: www.guden.com			
REVISIONS							
				GUDEN INDUSTRIAL HARDWARE MADE EASY 99 RAYNOR AVE. RONKONKOMA, N.Y. 11779 1-800-3-HINGES			