

A
SIZE

PROJECTIONS

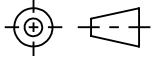

TOLERANCES UNLESS OTHERWISE SPECIFIED:

PLACES	INCHES	NOTES:
.XX	± .030	ACCEPTABLE BURR ± 10% OF MATERIAL THICKNESS
.XXX	± .015	ALL TOLERANCES ARE NON-CUMULATIVE
.XXXX	± .005	ALL DIMENSIONS APPLY TO PART BEFORE ANY
ANGLE	± 3°	FINISH IS APPLIED

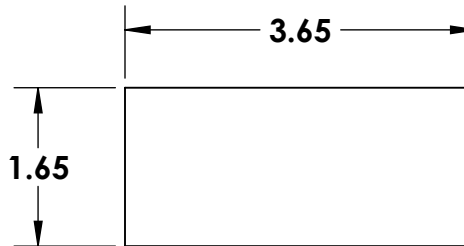
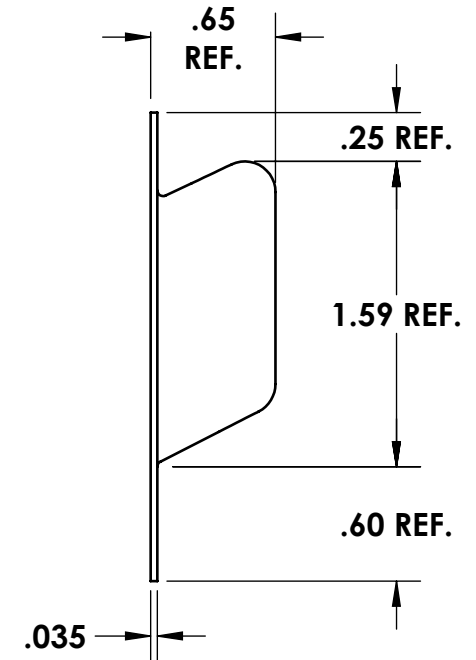
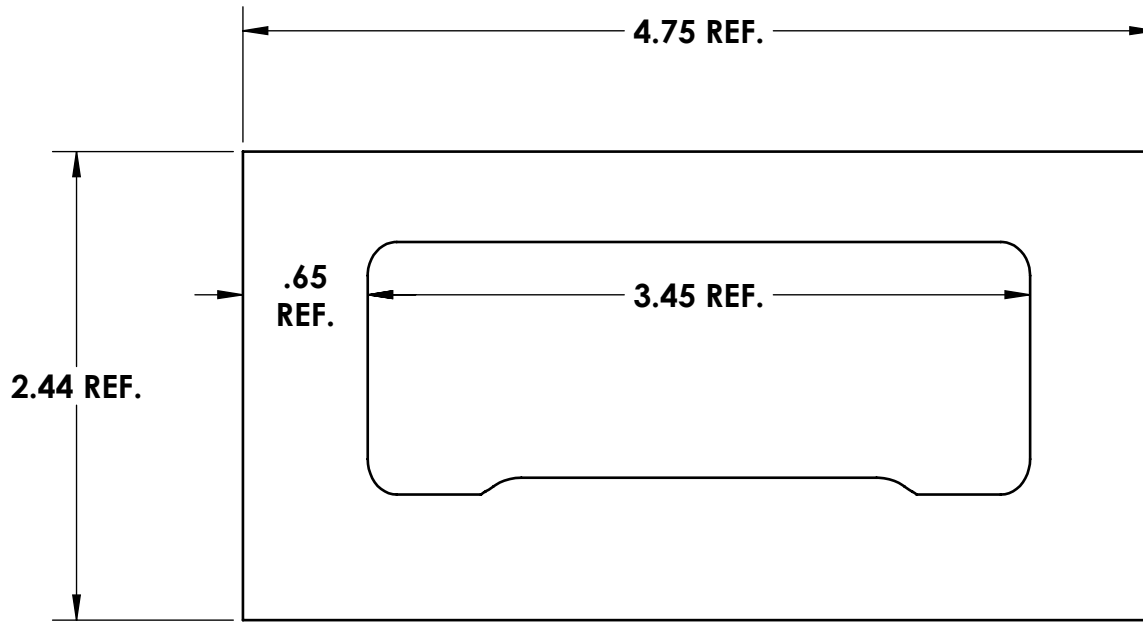

MOUNTING TEMPLATE

NOTES:

1. FINISH: 105- BARREL ZINC AND CLEAR TRIVALENT CHROMATE

REV.	DESCRIPTION	DATE	APPD
C	VARIOUS CHANGES	10/04/2023	JG
B	CONVERTED	03/30/2018	JG
A	VARIOUS DIM CHANGES	04/07/1995	RK

REVISIONS

DWG #:		SCALE	1:1	CODE IDENT. #
1898-02		DATE	11/30/1994	03007
MATERIAL:	FINISH:	 99 RAYNOR AVE. RONKONKOMA, N.Y. 11779 1-800-3-HINGES		
PS	SEE NOTE			
DR. BY: RAG	CK. BY: RK			
FAX: 1-631-737-2933 EMAIL: info@guden.com WEB: www.guden.com				