

**A**  
SIZE

PROJECTIONS

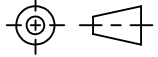

TOLERANCES UNLESS OTHERWISE SPECIFIED:

PLACES	INCHES	NOTES:
.XX	± .030	ACCEPTABLE BURR ± 10% OF MATERIAL THICKNESS
.XXX	± .015	ALL TOLERANCES ARE NON-CUMULATIVE
.XXXX	± .005	ALL DIMENSIONS APPLY TO PART BEFORE ANY
ANGLE	± 3°	FINISH IS APPLIED

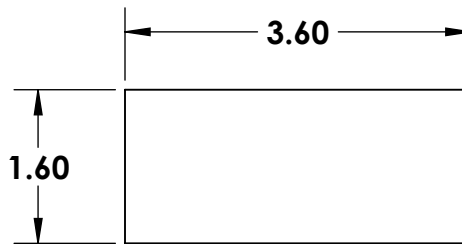
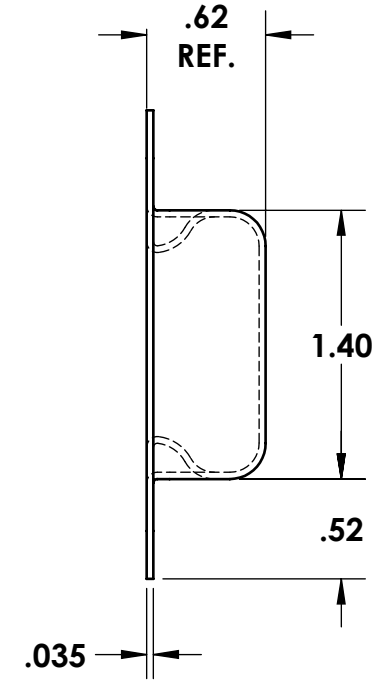
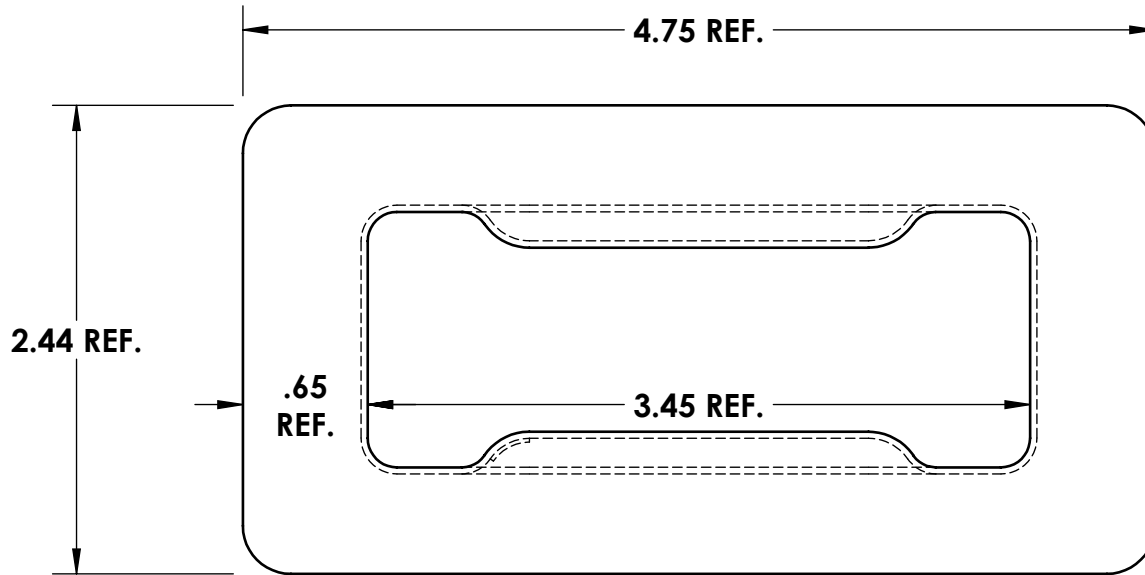

MOUNTING TEMPLATE

NOTES:  
1. FINISH: 29- BRUSHED TOPSIDE ONLY

<table border="1"> <tr> <td>E</td> <td>CONVERTED</td> <td>03/29/2018</td> <td>JG</td> </tr> <tr> <td>D</td> <td>1.40 WAS 1.50,.52 WAS .47</td> <td>10/10/2013</td> <td>JG</td> </tr> <tr> <td>C</td> <td>VARIOUS DIM CHANGES</td> <td>04/07/1995</td> <td>CD</td> </tr> <tr> <td>REV.</td> <td>DESCRIPTION</td> <td>DATE</td> <td>APPD</td> </tr> <tr> <td colspan="4" style="text-align: center;">REVISIONS</td> </tr> </table>				E	CONVERTED	03/29/2018	JG	D	1.40 WAS 1.50,.52 WAS .47	10/10/2013	JG	C	VARIOUS DIM CHANGES	04/07/1995	CD	REV.	DESCRIPTION	DATE	APPD	REVISIONS				DWG #: <b>1896-32D</b>		SCALE	1:1	CODE IDENT. #
				E	CONVERTED	03/29/2018	JG																					
D	1.40 WAS 1.50,.52 WAS .47	10/10/2013	JG																									
C	VARIOUS DIM CHANGES	04/07/1995	CD																									
REV.	DESCRIPTION	DATE	APPD																									
REVISIONS																												
				DATE	02/06/1990	03007																						
				MATERIAL:	FINISH:																							
				304-ST5	SEE NOTE																							
				DR. BY: CJD	CK. BY: AG																							
				FAX: 1-631-737-2933 EMAIL: info@guden.com WEB: www.guden.com		 99 RAYNOR AVE. RONKONKOMA, N.Y. 11779 1-800-3-HINGES																						