

**A**  
SIZE

PROJECTIONS

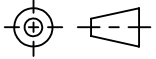

TOLERANCES UNLESS OTHERWISE SPECIFIED:

PLACES	INCHES	NOTES:
.XX	± .030	ACCEPTABLE BURR ± 10% OF MATERIAL THICKNESS
.XXX	± .015	ALL TOLERANCES ARE NON-CUMULATIVE
.XXXX	± .005	ALL DIMENSIONS APPLY TO PART BEFORE ANY
ANGLE	± 3°	FINISH IS APPLIED

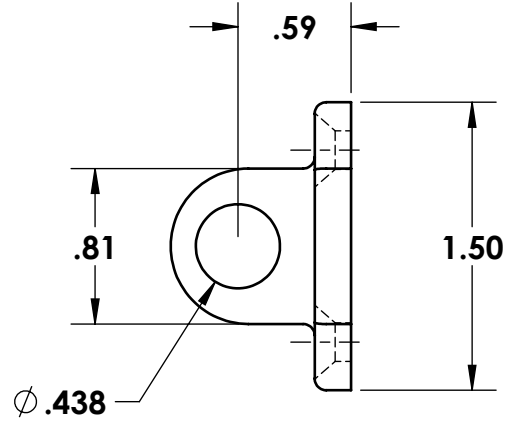
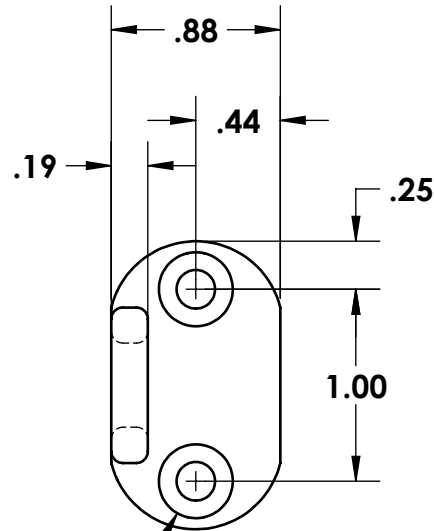

2X #10 OVAL HEAD  
MACHINE SCREW

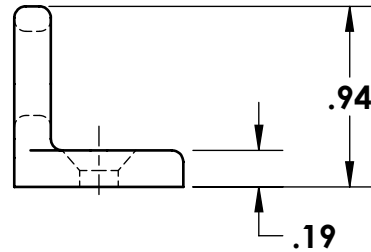

**NOTES:**

1. FINISH: 78- SATIN NICKEL
2. TOLERANCE: (2 PL) .XX ± .060

DWG #:		SCALE	1:1	CODE IDENT. #
<b>8234-15</b>		DATE	11/16/1999	03007
MATERIAL:	FINISH:	 <b>INDUSTRIAL HARDWARE MADE EASY</b> 99 RAYNOR AVE. RONKONKOMA, N.Y. 11779 1-800-3-HINGES		
BRASS	SEE NOTE			
DR. BY: RAG	CK. BY: CD			
FAX: 1-631-737-2933 EMAIL: info@guden.com WEB: www.guden.com				

REV.	DESCRIPTION	DATE	APPD
B	CONVERTED	07/10/2019	JG
A	ADDED TOLERANCE NOTE	10/23/2012	JG
REVISIONS			