

A
SIZE

PROJECTIONS

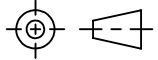

TOLERANCES UNLESS OTHERWISE SPECIFIED:

PLACES	INCHES	NOTES:
.XX	± .030	ACCEPTABLE BURR ± 10% OF MATERIAL THICKNESS
.XXX	± .015	ALL TOLERANCES ARE NON-CUMULATIVE
.XXXX	± .005	ALL DIMENSIONS APPLY TO PART BEFORE ANY
ANGLE	± 3°	FINISH IS APPLIED

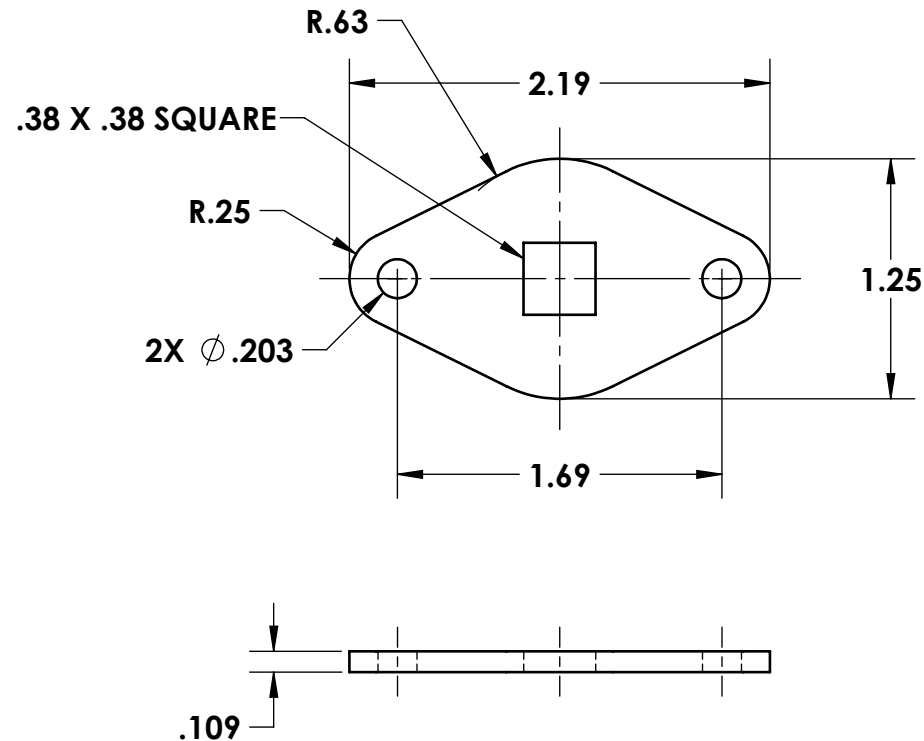

NOTES:
1. FINISH: 90- BARREL ZINC AND CLEAR CHROMATE

REV. DESCRIPTION DATE APPD				DWG #:	SCALE	1:1	CODE IDENT. #
C	CONVERTED	07/08/2019	JG	8213-02	DATE	08/13/1999	03007
B	CLINES, RADII	01/07/2009	CD		MATERIAL: PS	FINISH: SEE NOTE	
A	REDRAWN	08/13/1999	CD	DR. BY: RAG	CK. BY: CD		GUDEN INDUSTRIAL HARDWARE MADE EASY 99 RAYNOR AVE. RONKONKOMA, N.Y. 11779 1-800-3-HINGES
REV.	DESCRIPTION	DATE	APPD	FAX: 1-631-737-2933 EMAIL: info@guden.com WEB: www.guden.com			
REVISIONS							