

A
SIZE

PROJECTIONS

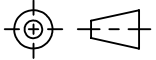

TOLERANCES UNLESS OTHERWISE SPECIFIED:

PLACES	INCHES	NOTES:
.XX	± .030	ACCEPTABLE BURR ± 10% OF MATERIAL THICKNESS
.XXX	± .015	ALL TOLERANCES ARE NON-CUMULATIVE
.XXXX	± .005	ALL DIMENSIONS APPLY TO PART BEFORE ANY FINISH IS APPLIED
ANGLE	± 3°	

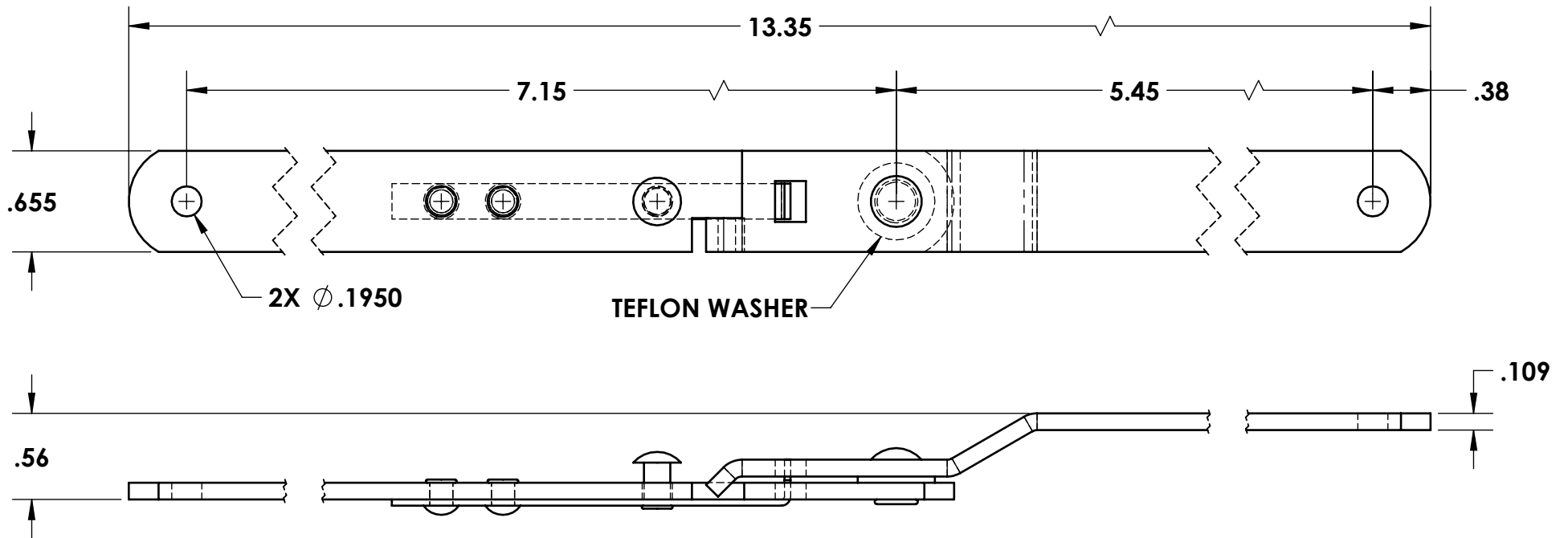
**NOTES:**

1. FINISH: 105- BARREL ZINC AND CLEAR TRIVALENT CHROMATE
2. STAMP "LH" OR "L" ON PART
3. INDIVIDUAL PART WITH (2) TRUSS HEAD SCREWS AND INSTALLATION INSTRUCTIONS PACKED IN A BOX

E	VARIOUS CHANGES	08/22/2018	JG	DWG #: 7793LH-02	SCALE	1:1	CODE IDENT. #
D	VARIOUS CHANGES	04/09/2018	JG		DATE	04/21/1998	03007
C	CHANGED FINISH	09/28/2016	JG	MATERIAL: PS	FINISH: SEE NOTE		
B	VARIOUS CHANGES	08/10/2012	JG	DR. BY: RAG	CK. BY: CD		
REV.	DESCRIPTION	DATE	APPD	FAX: 1-631-737-2933 EMAIL: info@guden.com WEB: www.guden.com			
REVISIONS							
				GUDEN INDUSTRIAL HARDWARE MADE EASY 99 RAYNOR AVE. RONKONKOMA, N.Y. 11779 1-800-3-HINGES			