

A
SIZE

PROJECTIONS

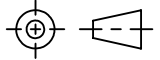

TOLERANCES UNLESS OTHERWISE SPECIFIED:

PLACES	INCHES	NOTES:
.XX	± .030	ACCEPTABLE BURR ± 10% OF MATERIAL THICKNESS
.XXX	± .015	ALL TOLERANCES ARE NON-CUMULATIVE
.XXXX	± .005	ALL DIMENSIONS APPLY TO PART BEFORE ANY
ANGLE	± 3°	FINISH IS APPLIED

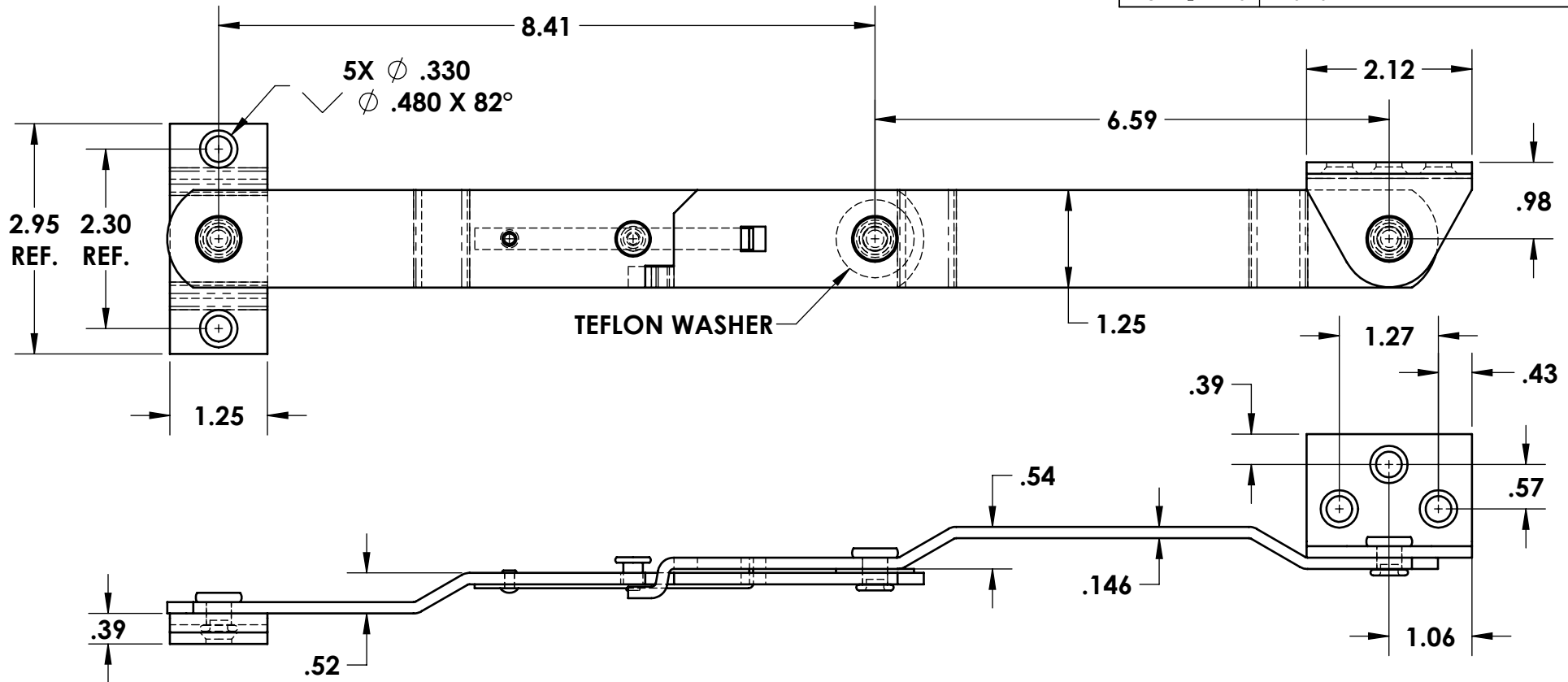

NOTES:

1. FINISH: 108- RACK ZINC AND CLEAR TRIVALENT CHROMATE
2. STAMP "RH" OR "R" ON PART
3. INDIVIDUAL PART WITH (5) FLAT HEAD SCREWS AND INSTALLATION INSTRUCTIONS PACKED IN A BOX
4. MOUNTING BRACKETS SHOULD BE FREE SWINGING

REV.	DESCRIPTION	DATE	APPD
D	VARIOUS CHANGES	08/22/2018	JG
C	ADDED NOTE 5	05/16/2018	JG
B	VARIOUS CHANGES	04/09/2018	JG

REVISIONS

DWG #:		SCALE	1:2	CODE IDENT. #
7791RH-02		DATE	03/20/1998	03007
MATERIAL:	FINISH:	 99 RAYNOR AVE. RONKONKOMA, N.Y. 11779 1-800-3-HINGES		
PS	SEE NOTE			
DR. BY: RAG	CK. BY: CD			
FAX: 1-631-737-2933 EMAIL: info@guden.com WEB: www.guden.com				