

A
SIZE

PROJECTIONS



TOLERANCES UNLESS OTHERWISE SPECIFIED:

PLACES	INCH	NOTE:
.XX	± .030	ACCEPTABLE BURR ± 10% OF MATERIAL THICKNESS ALL TOLERANCES ARE NON-CUMULATIVE ALL DIMENSIONS APPLY TO PART BEFORE ANY FINISH IS APPLIED
.XXX	± .015	
.XXXX	± .005	
ANGLE	± 3°	

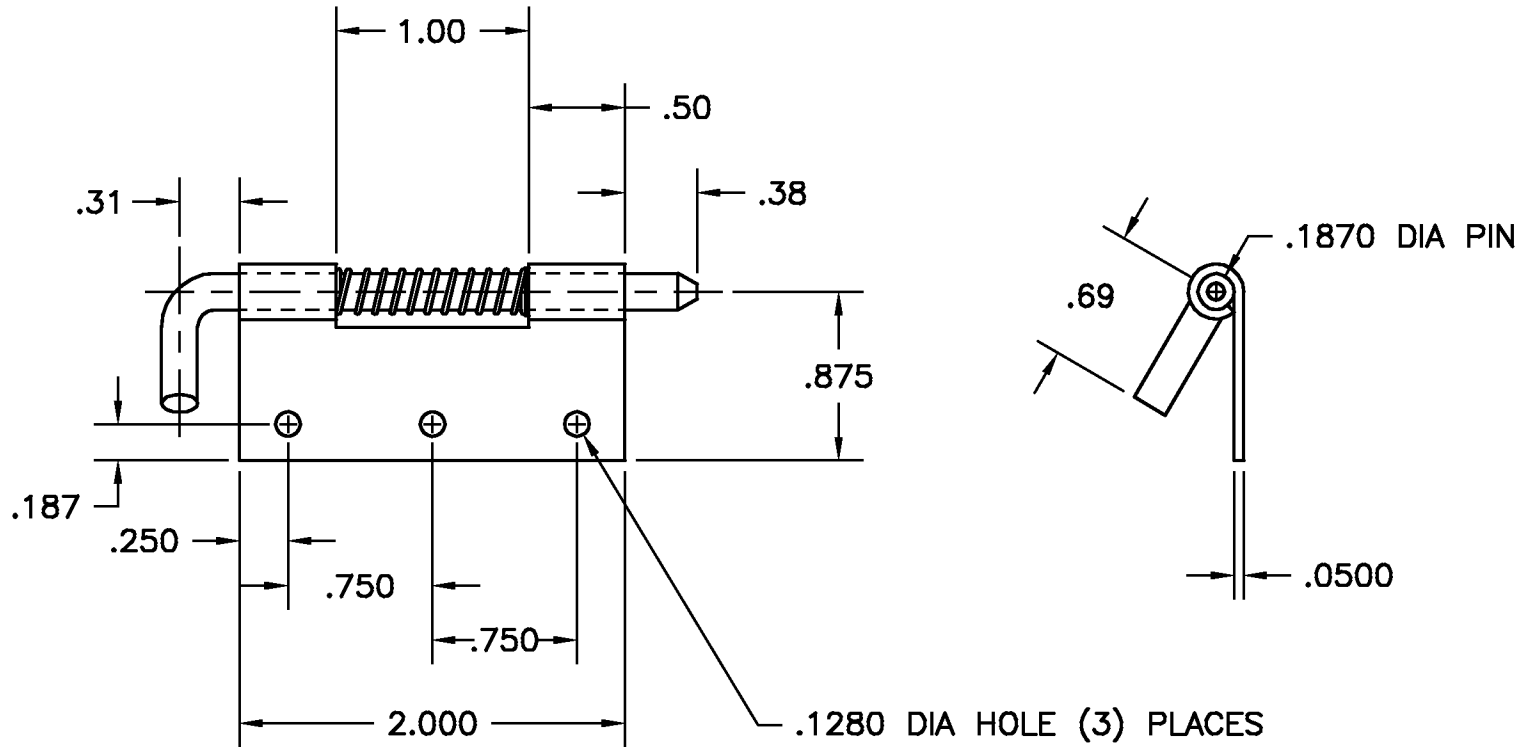

NOTES:

- FINISH: 105- BARREL ZINC AND CLEAR TRIVALENT CHROMATE
- MATERIAL: LEAF & PIN = PS
SPRING & CLIP = STS

LTR	DESCRIPTION	DATE	APPD
C	VARIOUS CHANGES	02/24/15	JG
B	ADDED PIN DIMS	01/16/06	CD
A	MATERIAL NOTE	10/05/05	CD
REVISION			

DWG
H9294RH-02

MATERIAL: SEE NOTE
FINISH: SEE NOTE
DR. BY RAG
CK. BY CD

FAX: 1-631-737-2933
EMAIL: info@guden.com
WEB: www.guden.com

SCALE	1:1	CODE IDENT. #
DATE	11/08/96	03007



99 RAYNOR AVE.
RONKONKOMA, N.Y. 11779
1-800-3-HINGES