

A  
SIZE

PROJECTIONS



TOLERANCES UNLESS OTHERWISE SPECIFIED:

PLACES	INCH	NOTE:
.XX	± .030	ACCEPTABLE BURR ± 10% OF MATERIAL THICKNESS ALL TOLERANCES ARE NON-CUMULATIVE ALL DIMENSIONS APPLY TO PART BEFORE ANY FINISH IS APPLIED
.XXX	± .015	
.XXXX	± .005	
ANGLE	± 3°	

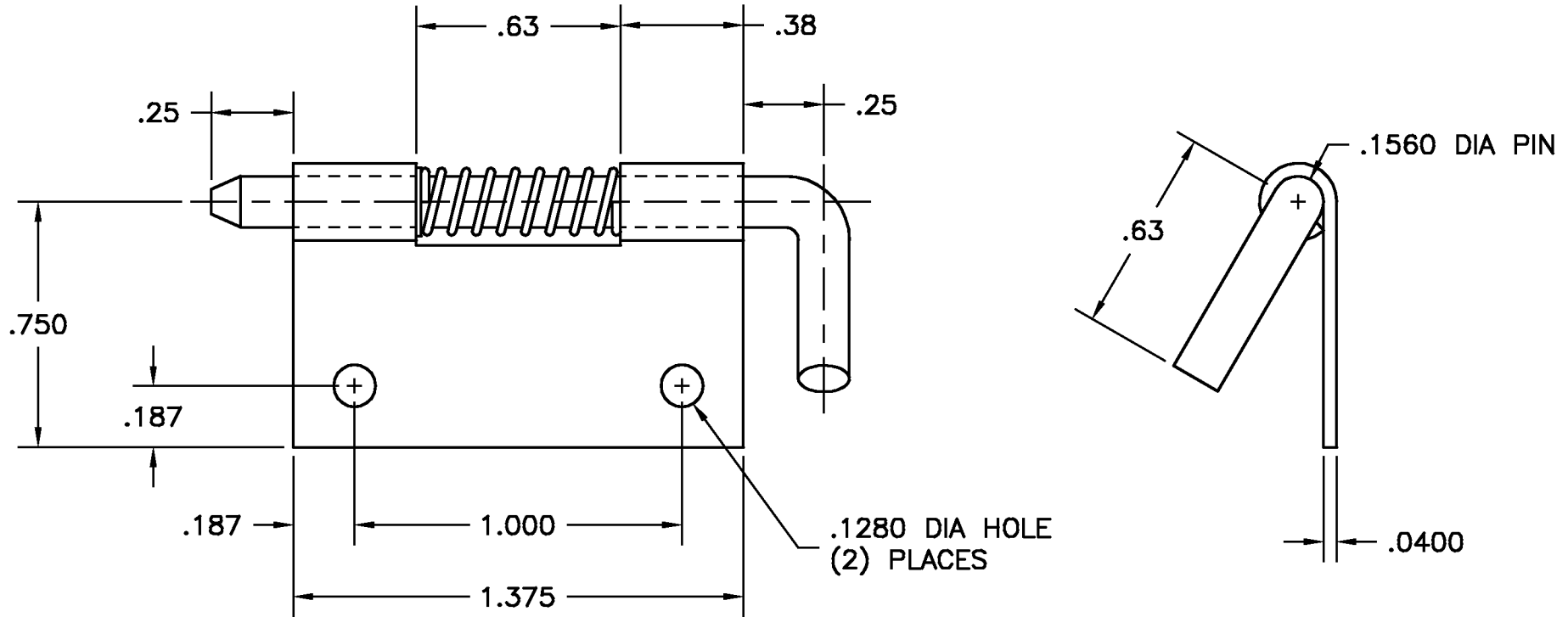

NOTES:

1. FINISH: 105- BARREL ZINC AND CLEAR TRIVALENT CHROMATE
2. MATERIAL: LEAF & PIN = PS  
SPRING & CLIP = STS

DWG H9293LH-02		SCALE 2:1	CODE IDENT. # 03007
MATERIAL SEE NOTE		DATE 06/20/16	
FINISH SEE NOTE		DR. BY RAG CK. BY JG	
DR. BY RAG CK. BY JG			
FAX: 1-631-737-2933 EMAIL: info@guden.com WEB: www.guden.com		99 RAYNOR AVE. RONKONKOMA, N.Y. 11779 1-800-3-HINGES	

LTR	DESCRIPTION	DATE	APPD
	REVISION		