

A
SIZE

PROJECTIONS



TOLERANCES UNLESS OTHERWISE SPECIFIED:

PLACES	INCH
.XX	± .030
.XXX	± .015
.XXXX	± .005
ANGLE	3°

NOTE:
ACCEPTABLE BURR ± 10% OF MATERIAL THICKNESS
ALL TOLERANCES ARE NON-CUMULATIVE
ALL DIMENSIONS APPLY TO PART BEFORE ANY FINISH IS APPLIED

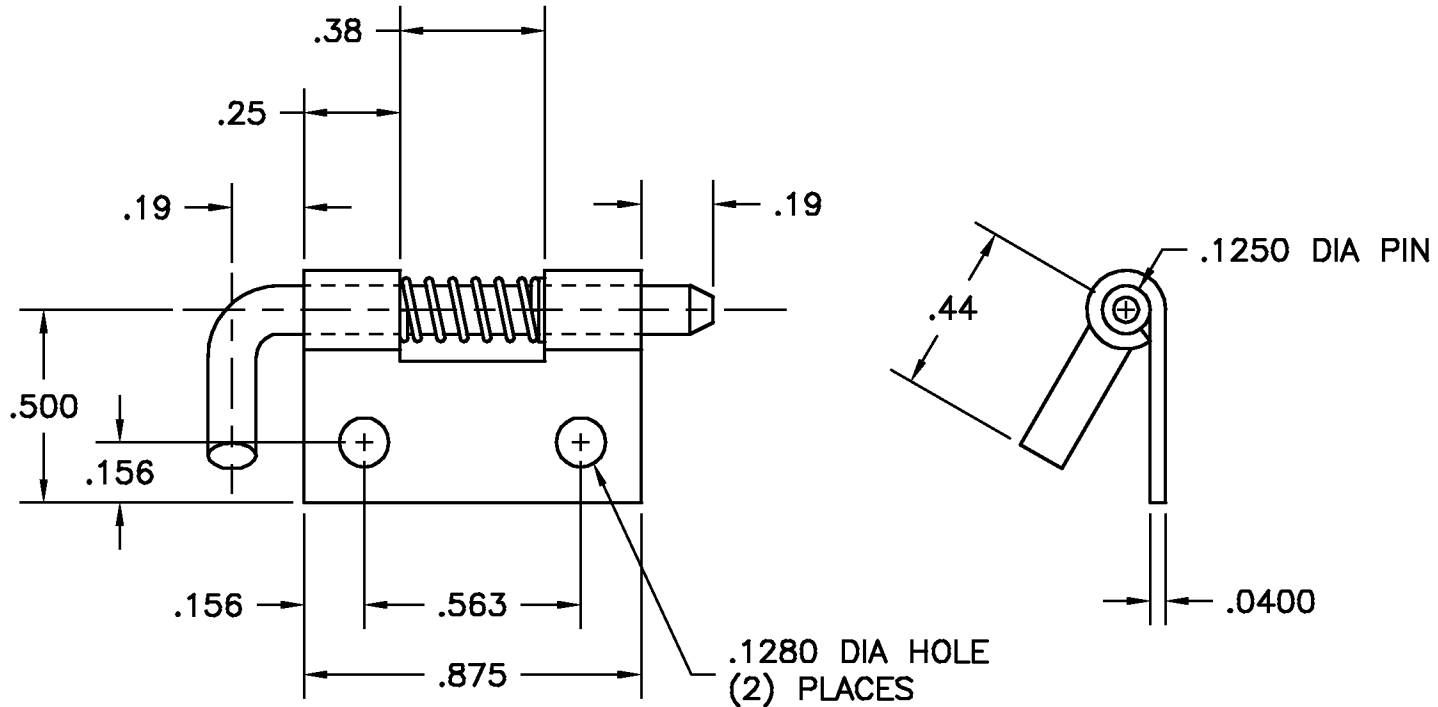

- NOTES:
1. FINISH: 105- BARREL ZINC AND CLEAR TRIVALENT CHROMATE
2. MATERIAL: LEAF & PIN = PS
SPRING & CLIP = STS

DWG H9292RH-02		SCALE 2:1	CODE IDENT. # 03007
MATERIAL SEE NOTE		DATE 06/15/16	
FINISH SEE NOTE		DR. BY RAG CK. BY JPG	
DR. BY RAG CK. BY JPG			
FAX: 1-631-737-2933 EMAIL: info@guden.com WEB: www.guden.com		99 RAYNOR AVE. RONKONKOMA, N.Y. 11779 1-800-3-HINGES	

LTR	DESCRIPTION	DATE	APPD
	REVISION		