

**B**  
SIZE

PROJECTIONS

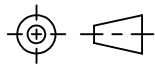

TOLERANCES UNLESS OTHERWISE SPECIFIED:

PLACES	INCHES	NOTES:
.XX	± .030	ACCEPTABLE BURR ± 10% OF MATERIAL THICKNESS
.XXX	± .015	ALL TOLERANCES ARE NON-CUMULATIVE
.XXXX	± .005	ALL DIMENSIONS APPLY TO PART BEFORE ANY
ANGLE	± 3°	FINISH IS APPLIED

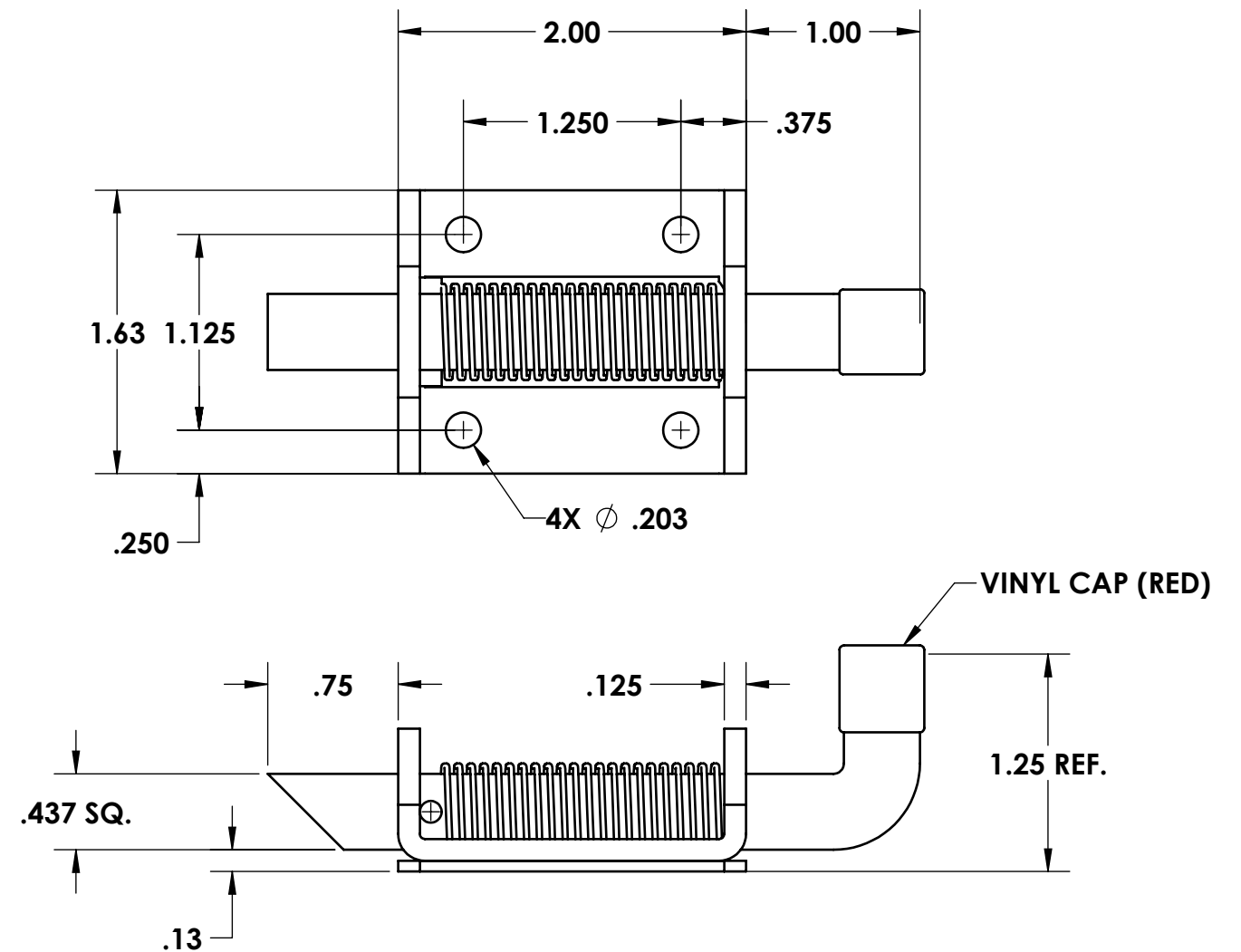
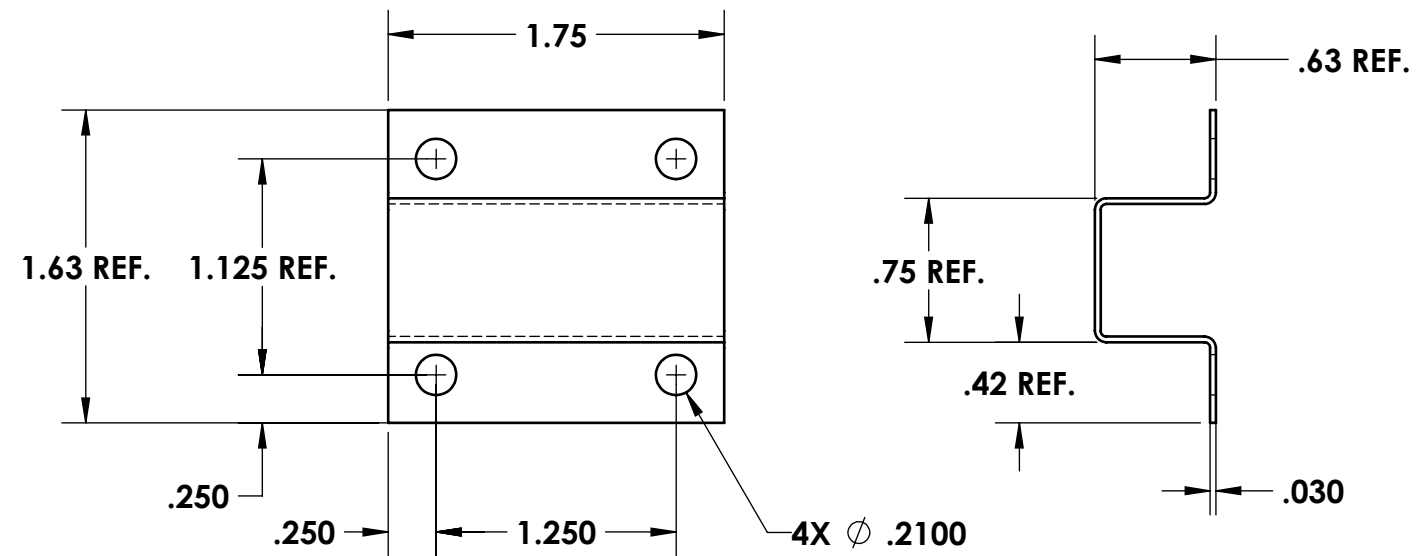

NOTES:  
1. FINISH: 26- PASSIVATE

REV.	DESCRIPTION	DATE	APPD
C	CONVERTED	05/10/2017	JG
B	REMOVED PACKAGE NOTE	06/22/2009	JG
A	ADDED PACKAGE NOTE	10/13/2006	CD
REVISIONS			

DWG #:	9602-32	SCALE	1:1	CODE IDENT. #	
		DATE	03/29/2005	03007	
MATERIAL:	STS	FINISH:	SEE NOTE	 <b>GUDEN</b> INDUSTRIAL HARDWARE MADE EASY 99 RAYNOR AVE. RONKONKOMA, N.Y. 11779 1-800-3-HINGES	
DR. BY:	RAG	CK. BY:	CD		
FAX: 1-631-737-2933 EMAIL: info@guden.com WEB: www.guden.com					