

B
SIZE

PROJECTIONS

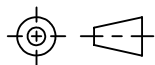

TOLERANCES UNLESS OTHERWISE SPECIFIED:

PLACES	INCHES	NOTES:
.XX	± .030	ACCEPTABLE BURR ± 10% OF MATERIAL THICKNESS
.XXX	± .015	ALL TOLERANCES ARE NON-CUMULATIVE
.XXXX	± .005	ALL DIMENSIONS APPLY TO PART BEFORE ANY
ANGLE	± 3°	FINISH IS APPLIED

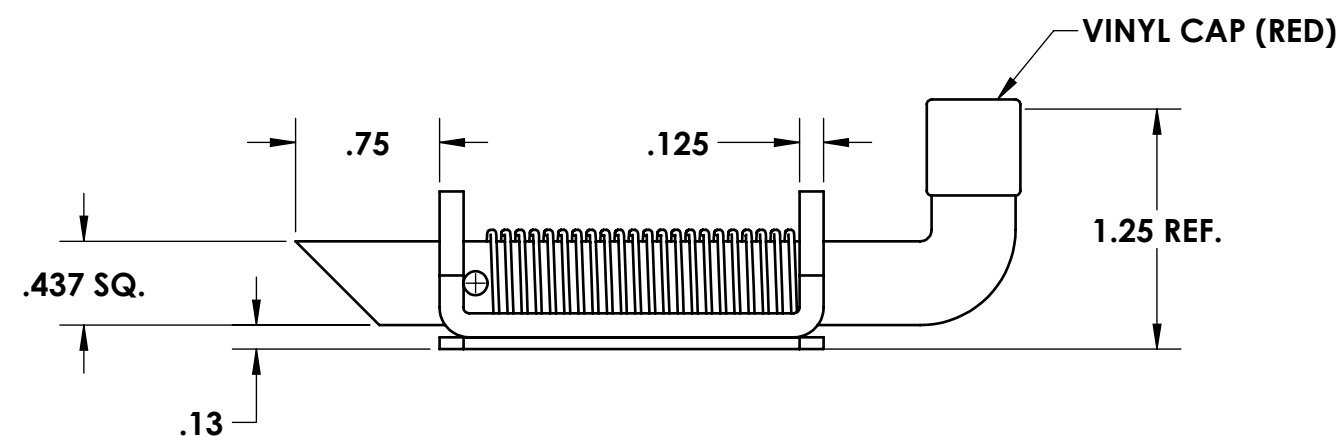
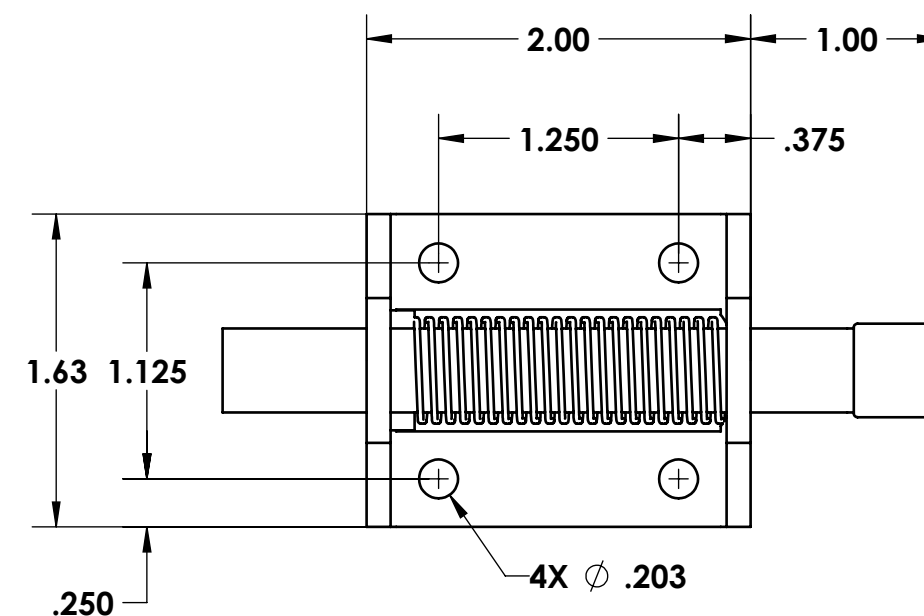
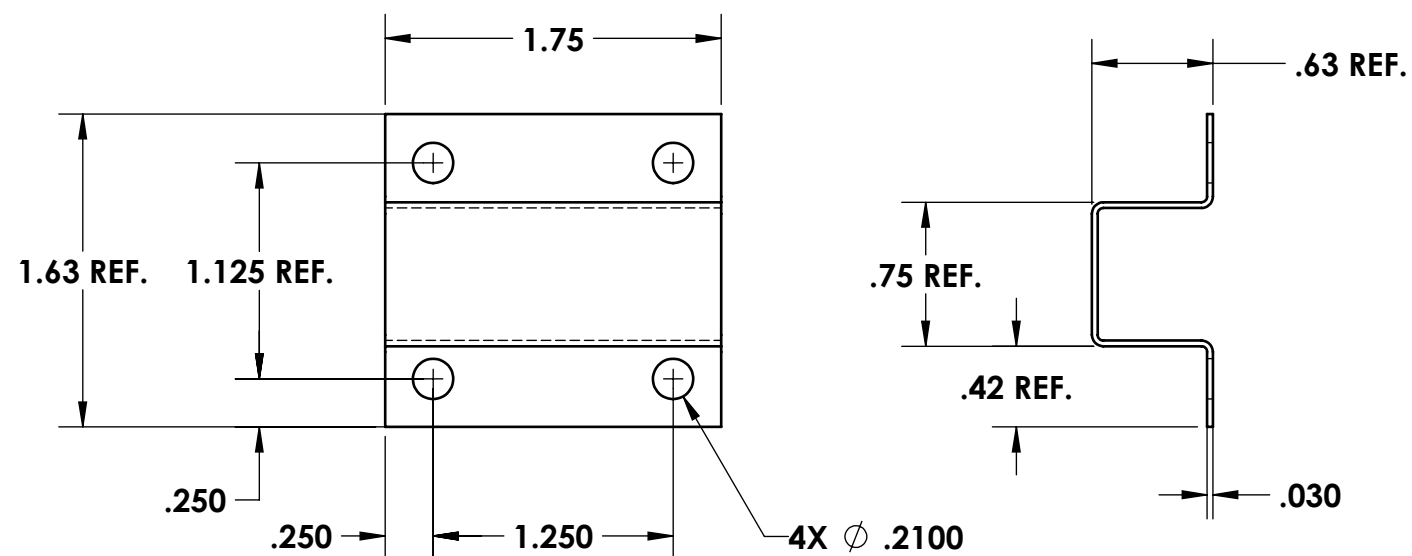

REV.	DESCRIPTION	DATE	APPD
D	CONVERTED, FINISH	05/10/2017	JG
C	REMOVED PACKAGE NOTE	06/22/2009	JG
B	ADDED PACKAGE NOTE	10/13/2006	CD
A	VARIOUS CHANGES (COVER)	04/02/1998	CD
REVISIONS			

NOTES:

1. FINISH: 105- BARREL ZINC AND CLEAR TRIVALENT CHROMATE

DWG #:

9602-02MATERIAL:
PSFINISH:
SEE NOTE

DR. BY: RAG

CK. BY: CD

FAX: 1-631-737-2933
EMAIL: info@guden.com
WEB: www.guden.com

SCALE

1:1

CODE IDENT. #

DATE

11/11/1996

03007

GUDEN

INDUSTRIAL HARDWARE MADE EASY

99 RAYNOR AVE.

RONKONKOMA, N.Y. 11779

1-800-3-HINGES