

A
SIZE

PROJECTIONS

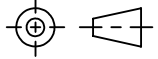

TOLERANCES UNLESS OTHERWISE SPECIFIED:

PLACES	INCHES	NOTES:
.XX	± .030	ACCEPTABLE BURR ± 10% OF MATERIAL THICKNESS
.XXX	± .015	ALL TOLERANCES ARE NON-CUMULATIVE
.XXXX	± .005	ALL DIMENSIONS APPLY TO PART BEFORE ANY FINISH IS APPLIED
ANGLE	± 3°	

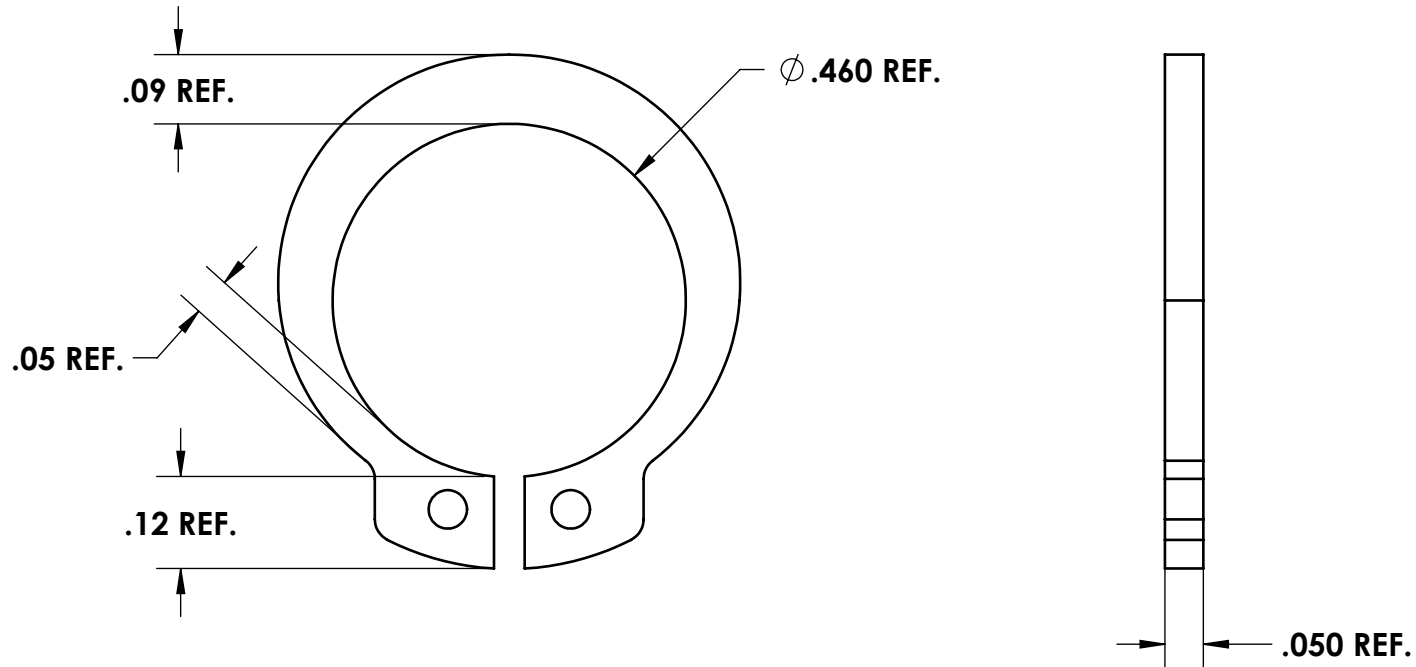

NOTES:

1. FINISH: 00- NO FINISH
2. FOR USE WITH 9297 PINS

DWG #:		SCALE	4:1	CODE IDENT. #
9297-32CLIP		DATE	03/27/2017	03007
MATERIAL:	FINISH:	 GUDEN INDUSTRIAL HARDWARE MADE EASY 99 RAYNOR AVE. RONKONKOMA, N.Y. 11779 1-800-3-HINGES		
STS	SEE NOTE			
DR. BY: RAG	CK. BY: JPG			
FAX: 1-631-737-2933				
EMAIL: info@guden.com				
WEB: www.guden.com				

REV.	DESCRIPTION	DATE	APPD
REVISIONS			