

**A**  
SIZE

PROJECTIONS

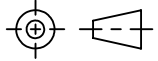

TOLERANCES UNLESS OTHERWISE SPECIFIED:

PLACES	INCHES	NOTES:
.XX	± .030	ACCEPTABLE BURR ± 10% OF MATERIAL THICKNESS
.XXX	± .015	ALL TOLERANCES ARE NON-CUMULATIVE
.XXXX	± .005	ALL DIMENSIONS APPLY TO PART BEFORE ANY FINISH IS APPLIED
ANGLE	± 3°	

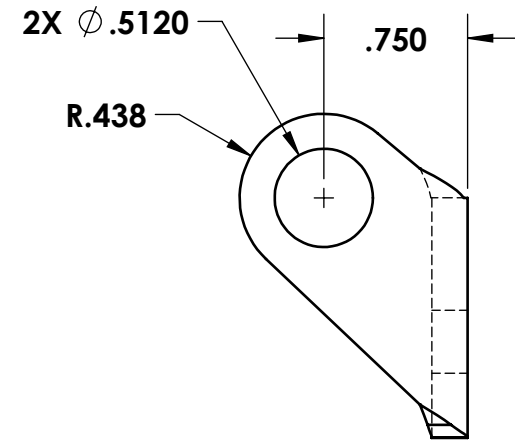
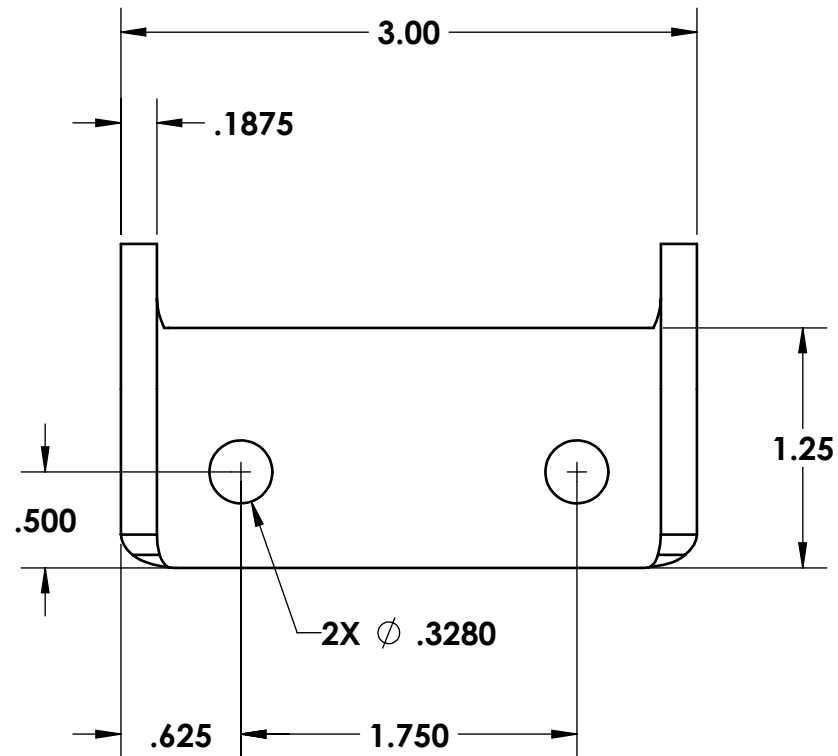

## NOTES:

- FINISH: 105- BARREL ZINC AND CLEAR TRIVALENT CHROMATE
- THRU HOLE (2 PL) TO BE // WITHIN .020 OF BOTTOM REF. .750 DIM.

DWG #:

**9297-02BODY**

SCALE

1:1

CODE IDENT. #

DATE

04/04/2017

03007

MATERIAL:  
PSFINISH:  
SEE NOTE

DR. BY: RAG

CK. BY: JPG

FAX: 1-631-737-2933

EMAIL: info@guden.com

WEB: www.guden.com

**GUDEN**

INDUSTRIAL HARDWARE MADE EASY

99 RAYNOR AVE.

RONKONKOMA, N.Y. 11779

1-800-3-HINGES

REV.	DESCRIPTION	DATE	APPD
	REVISIONS		