

A
SIZE

PROJECTIONS

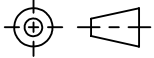

TOLERANCES UNLESS OTHERWISE SPECIFIED:

PLACES	INCHES	NOTES:
.XX	± .030	ACCEPTABLE BURR ± 10% OF MATERIAL THICKNESS
.XXX	± .015	ALL TOLERANCES ARE NON-CUMULATIVE
.XXXX	± .005	ALL DIMENSIONS APPLY TO PART BEFORE ANY FINISH IS APPLIED
ANGLE	± 3°	

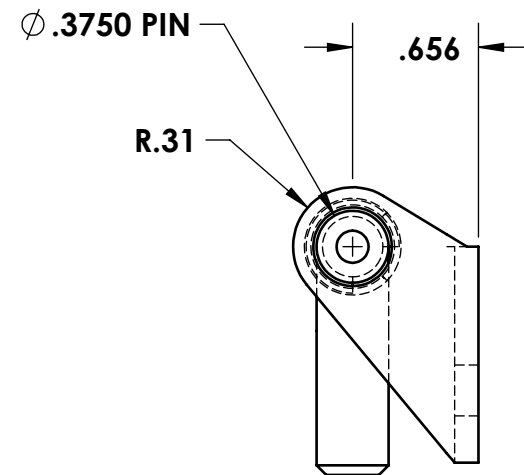
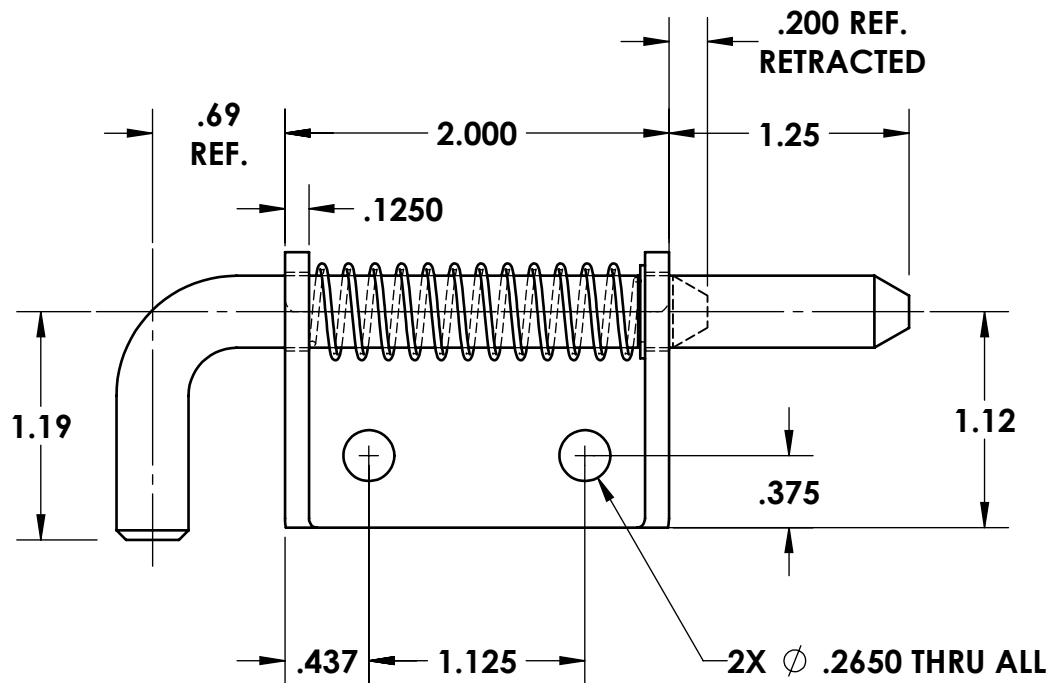

NOTES:

1. FINISH: 00- NO FINISH
2. THRU HOLE (2 PL) TO BE // WITHIN .020 OF BOTTOM. REF. .656 DIM.

REV.	DESCRIPTION	DATE	APPD	DWG #:	SCALE	1:1	CODE IDENT. #	
D	VARIOUS CHANGES	01/03/2019	JG	9296RH-32	DATE	07/31/1996	03007	
C	ADDED // NOTE	01/04/2002	CD					
B	VARIOUS CHANGES	07/24/2001	CD	MATERIAL:				FINISH:
A	ADDED RETRACTED DIM	03/19/1997	CD	304-ST5				SEE NOTE
REVISIONS				DR. BY: RAG				CK. BY: CD
				FAX: 1-631-737-2933 EMAIL: info@guden.com WEB: www.guden.com				