

A
SIZE

PROJECTIONS

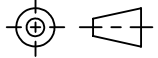

TOLERANCES UNLESS OTHERWISE SPECIFIED:

PLACES	INCHES	NOTES:
.XX	± .030	ACCEPTABLE BURR ± 10% OF MATERIAL THICKNESS
.XXX	± .015	ALL TOLERANCES ARE NON-CUMULATIVE
.XXXX	± .005	ALL DIMENSIONS APPLY TO PART BEFORE ANY FINISH IS APPLIED
ANGLE	± 3°	

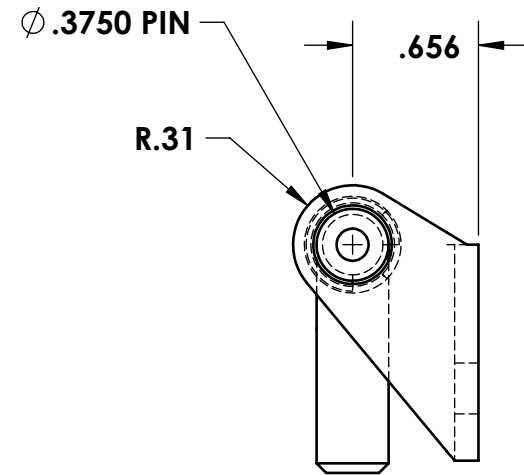
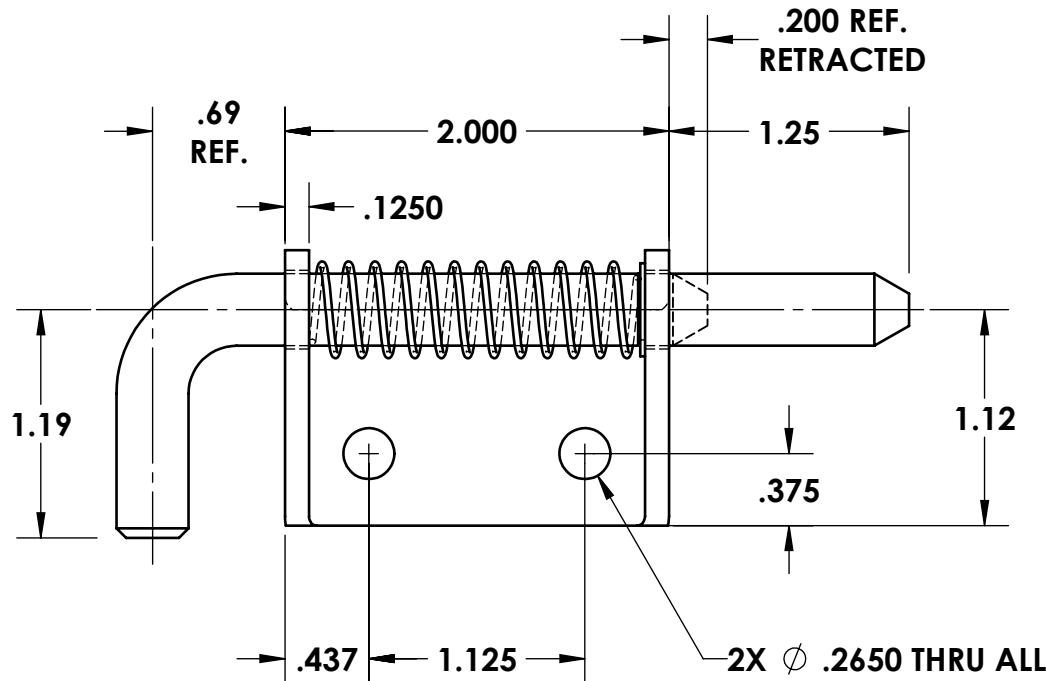

NOTES:

1. FINISH: 105 - BARREL ZINC AND CLEAR TRIVALENT CHROMATE
2. THRU HOLE (2 PL) TO BE // WITHIN .020 OF BOTTOM. REF. .656 DIM.

REV.	DESCRIPTION	DATE	APPD	DWG #:	SCALE	CODE IDENT. #
D	VARIOUS CHANGES	01/03/2019	JG	9296RH-02	1:1	03007
C	ADDED // NOTE	01/04/2002	CD		DATE	
B	VARIOUS CHANGES	07/24/2001	CD	MATERIAL: PS	FINISH: SEE NOTE	
A	ADDED RETRACTED DIM	03/19/1997	CD	DR. BY: RAG	CK. BY: CD	
REVISIONS				FAX: 1-631-737-2933 EMAIL: info@guden.com WEB: www.guden.com		 GUDEN INDUSTRIAL HARDWARE MADE EASY 99 RAYNOR AVE. RONKONKOMA, N.Y. 11779 1-800-3-HINGES