

A
SIZE

PROJECTIONS

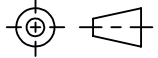

TOLERANCES UNLESS OTHERWISE SPECIFIED:

PLACES	INCHES	NOTES:
.XX	± .030	ACCEPTABLE BURR ± 10% OF MATERIAL THICKNESS
.XXX	± .015	ALL TOLERANCES ARE NON-CUMULATIVE
.XXXX	± .005	ALL DIMENSIONS APPLY TO PART BEFORE ANY FINISH IS APPLIED
ANGLE	± 3°	

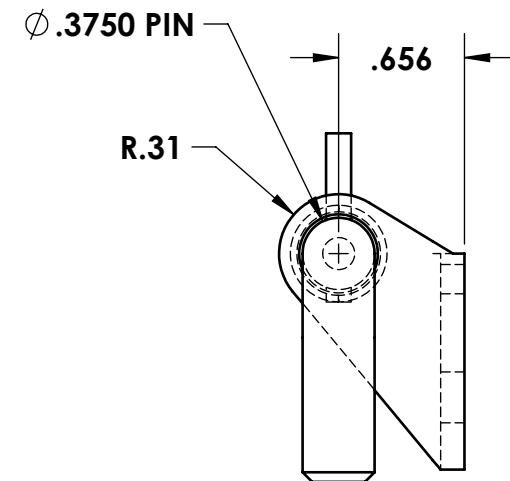
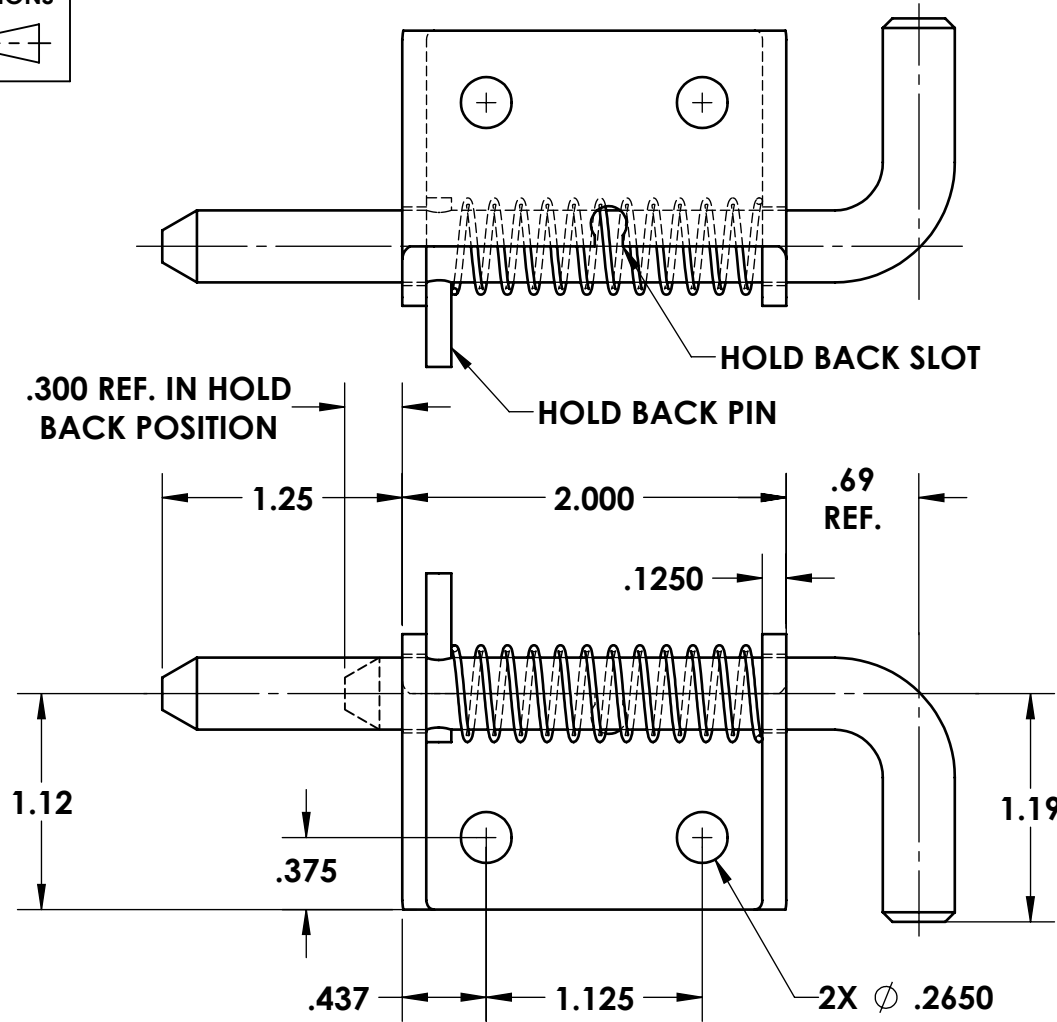

NOTES:

- FINISH: 105- BARREL ZINC AND CLEAR TRIVALENT CHROMATE
- THRU HOLE (2 PL) TO BE // WITHIN .020 OF BOTTOM. REF. .656 DIM.

DWG #:
9296LH-02-HB

SCALE	1:1	CODE IDENT. #
DATE	05/14/2003	03007

MATERIAL: PS
FINISH: SEE NOTE
DR. BY: RAG
CK. BY: CD



FAX: 1-631-737-2933
EMAIL: info@guden.com
WEB: www.guden.com

99 RAYNOR AVE.
RONKONKOMA, N.Y. 11779
1-800-3-HINGES

REV.	DESCRIPTION	DATE	APPD
A	VARIOUS CHANGES	01/03/2019	JG
REVISIONS			