

A  
SIZE

PROJECTIONS



TOLERANCES UNLESS OTHERWISE SPECIFIED:

PLACES	INCH
.XX	± .030
.XXX	± .015
.XXXX	± .005
ANGLE	3°

NOTE:  
ACCEPTABLE BURR ± 10% OF MATERIAL THICKNESS  
ALL TOLERANCES ARE NON-CUMULATIVE  
ALL DIMENSIONS APPLY TO PART BEFORE ANY FINISH IS APPLIED

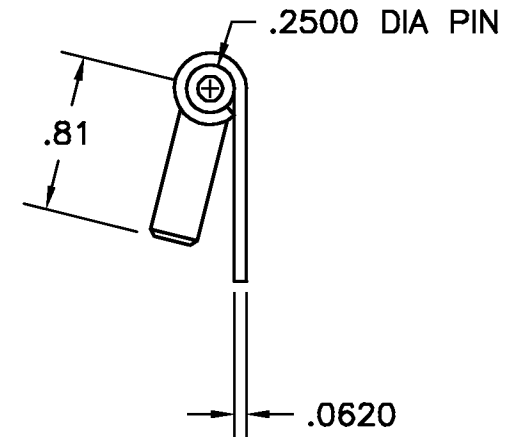
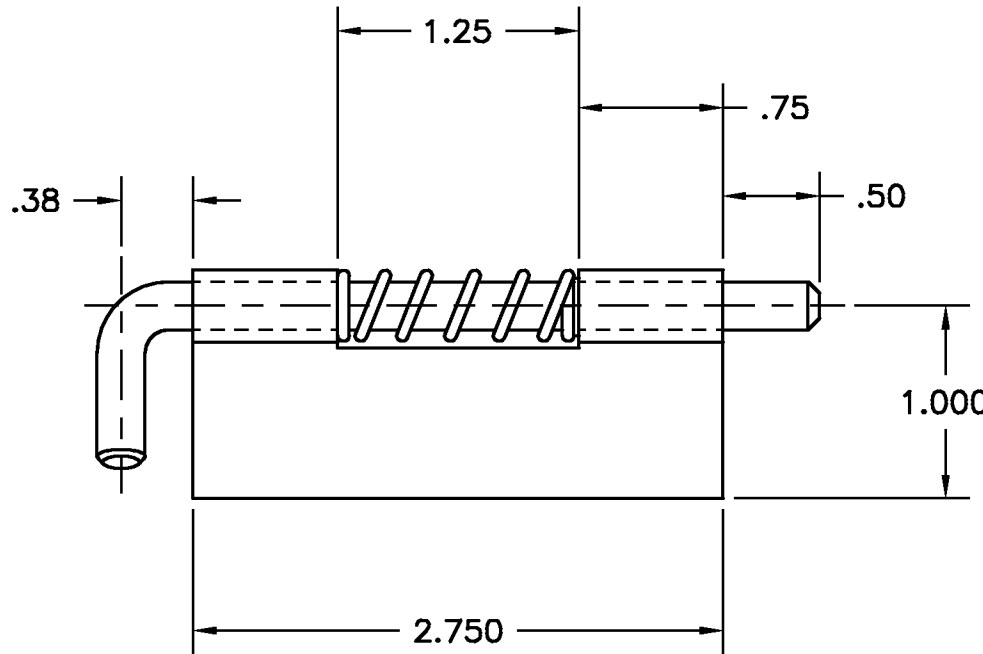

- NOTES:  
1. FINISH: 105- BARREL ZINC AND CLEAR TRIVALENT CHROMATE  
2. MATERIAL: LEAF & PIN = PS  
SPRING & CLIP = STS

LTR	REVISION	DESCRIPTION	DATE	APPD
E	.50 WAS .500		02/24/15	JG
D	1.25 WAS 1.250		09/10/13	JG
C	CHANGED FINISH		06/29/11	JG
B	ADDED PIN DIMS		01/16/06	CD
A	MATERIAL NOTE		10/05/05	CD

DWG	
9295RH-02	
MATERIAL	FINISH
SEE NOTE	SEE NOTE
DR. BY RAG	CK. BY RK
FAX: 1-631-737-2933	
EMAIL: info@guden.com	
WEB: www.guden.com	

SCALE	1:1	CODE IDENT. #
DATE	05/01/95	03007
99 RAYNOR AVE. RONKONKOMA, N.Y. 11779 1-800-3-HINGES		