

**A**  
SIZE

PROJECTIONS



TOLERANCES UNLESS OTHERWISE SPECIFIED:

PLACES	INCH
.XX	± .030
.XXX	± .015
.XXXX	± .005
ANGLE	3°

NOTE:  
ACCEPTABLE BURR ± 10% OF MATERIAL THICKNESS  
ALL TOLERANCES ARE NON-CUMULATIVE  
ALL DIMENSIONS APPLY TO PART BEFORE ANY FINISH IS APPLIED

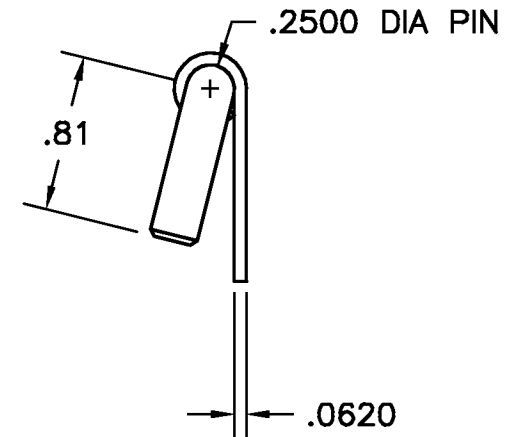
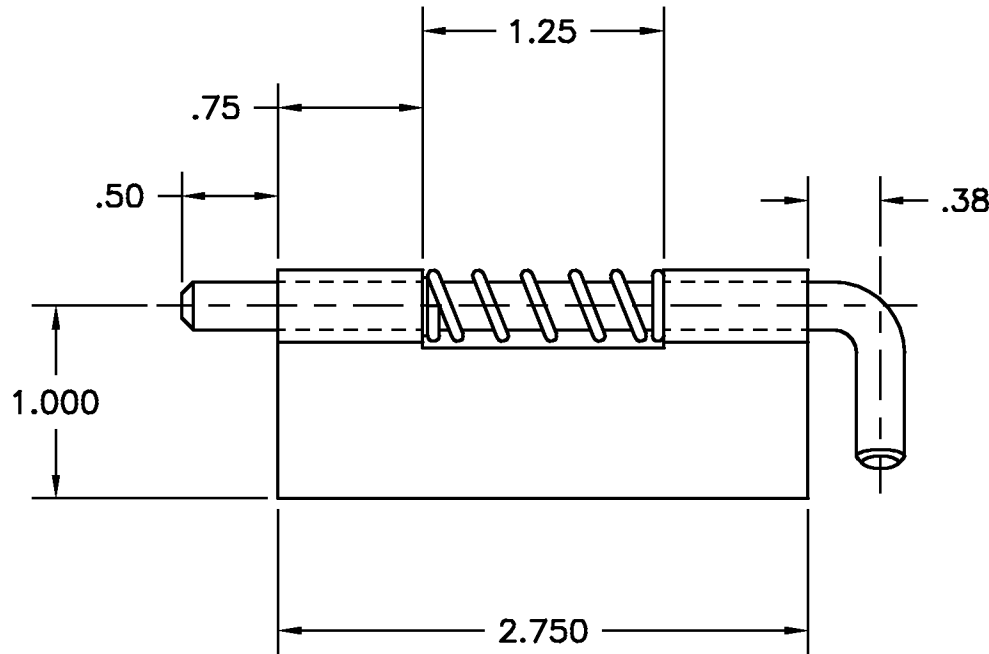

NOTES:  
1. FINISH: 00- NO FINISH

DWG		SCALE	1:1	CODE IDENT. #
9295LH-32		DATE	05/01/95	03007
MATERIAL	FINISH			
STS	SEE NOTE			
DR. BY RAG	CK. BY RK	99 RAYNOR AVE. RONKONKOMA, N.Y. 11779 1-800-3-HINGES		
FAX: 1-631-737-2933 EMAIL: info@guden.com WEB: www.guden.com				

LTR	DESCRIPTION	DATE	APPD
C	.50 WAS .500	03/23/15	JG
B	1.25 WAS 1.250	09/10/13	JG
A	ADDED PIN DIMS	01/16/06	CD
REVISION			