

A
SIZE

PROJECTIONS



TOLERANCES UNLESS OTHERWISE SPECIFIED:

PLACES	INCH	NOTE:
.XX	± .030	ACCEPTABLE BURR ± 10% OF MATERIAL THICKNESS ALL TOLERANCES ARE NON-CUMULATIVE ALL DIMENSIONS APPLY TO PART BEFORE ANY FINISH IS APPLIED
.XXX	± .015	
.XXXX	± .005	
ANGLE	3°	

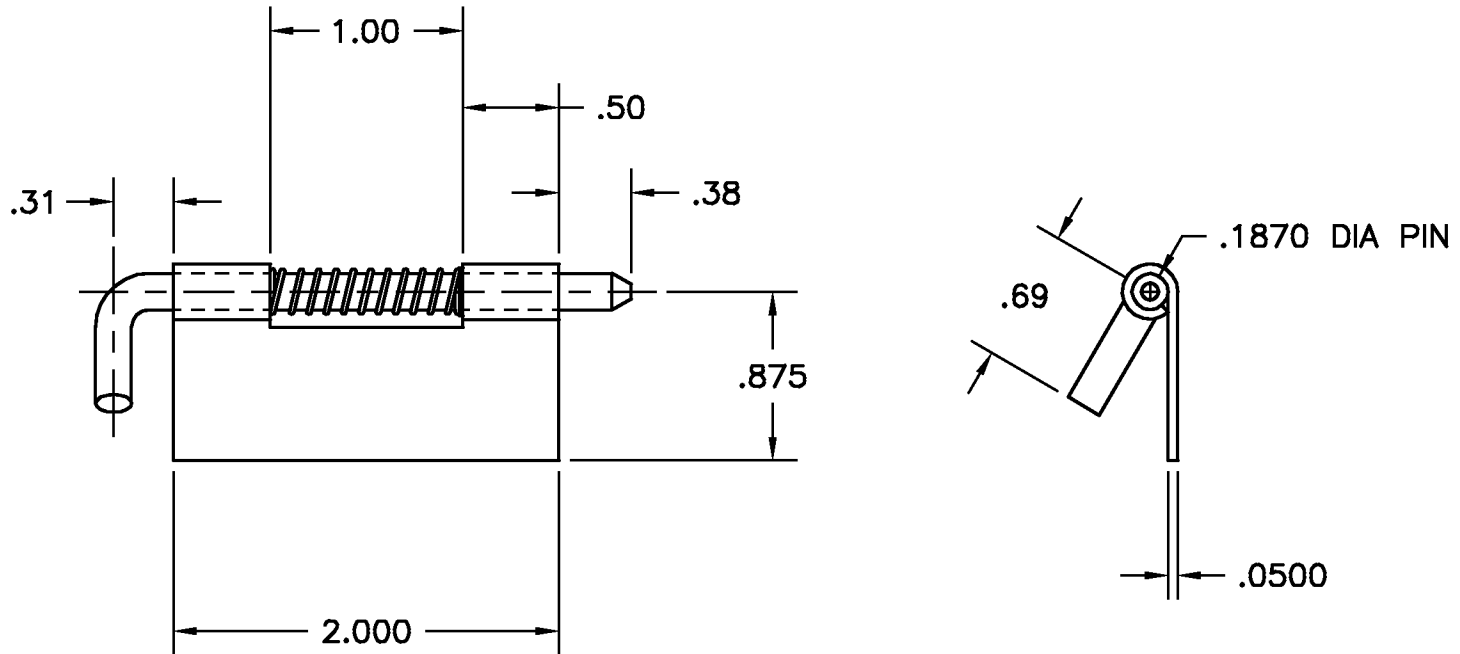

- NOTES:
 1. FINISH: 105- BARREL ZINC AND CLEAR TRIVALENT CHROMATE
 2. MATERIAL: LEAF & PIN = PS
 SPRING & CLIP = STS

D	REVISION	DESCRIPTION	DATE	APPD
D	1.00 WAS 1.000		02/24/15	JG
C	VARIOUS CHANGES		11/21/12	JG
B	ADDED PIN DIMS		01/16/06	CD
A	MATERIAL NOTE		10/05/05	CD
LTR				

DWG 9294RH-02		SCALE 1:1	CODE IDENT. # 03007
MATERIAL SEE NOTE		DATE 05/01/95	
FINISH SEE NOTE		DR. BY RAG	
DR. BY RAG		CK. BY RK	
FAX: 1-631-737-2933		GUDEN DELIVERING HARDWARE EXCELLENCE 99 RAYNOR AVE. RONKONKOMA, N.Y. 11779 1-800-3-HINGES	
EMAIL: info@guden.com			
WEB: www.guden.com			