

A
SIZE

PROJECTIONS

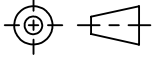

TOLERANCES UNLESS OTHERWISE SPECIFIED:

PLACES	INCHES	NOTES:
.XX	± .030	ACCEPTABLE BURR ± 10% OF MATERIAL THICKNESS
.XXX	± .015	ALL TOLERANCES ARE NON-CUMULATIVE
.XXXX	± .005	ALL DIMENSIONS APPLY TO PART BEFORE ANY FINISH IS APPLIED
ANGLE	± 3°	

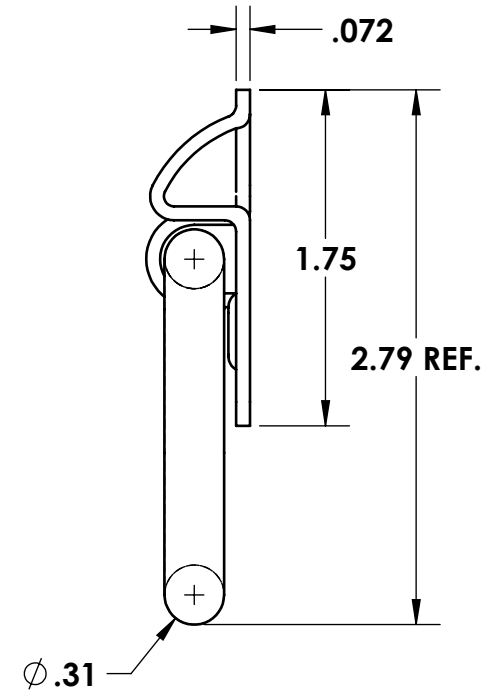
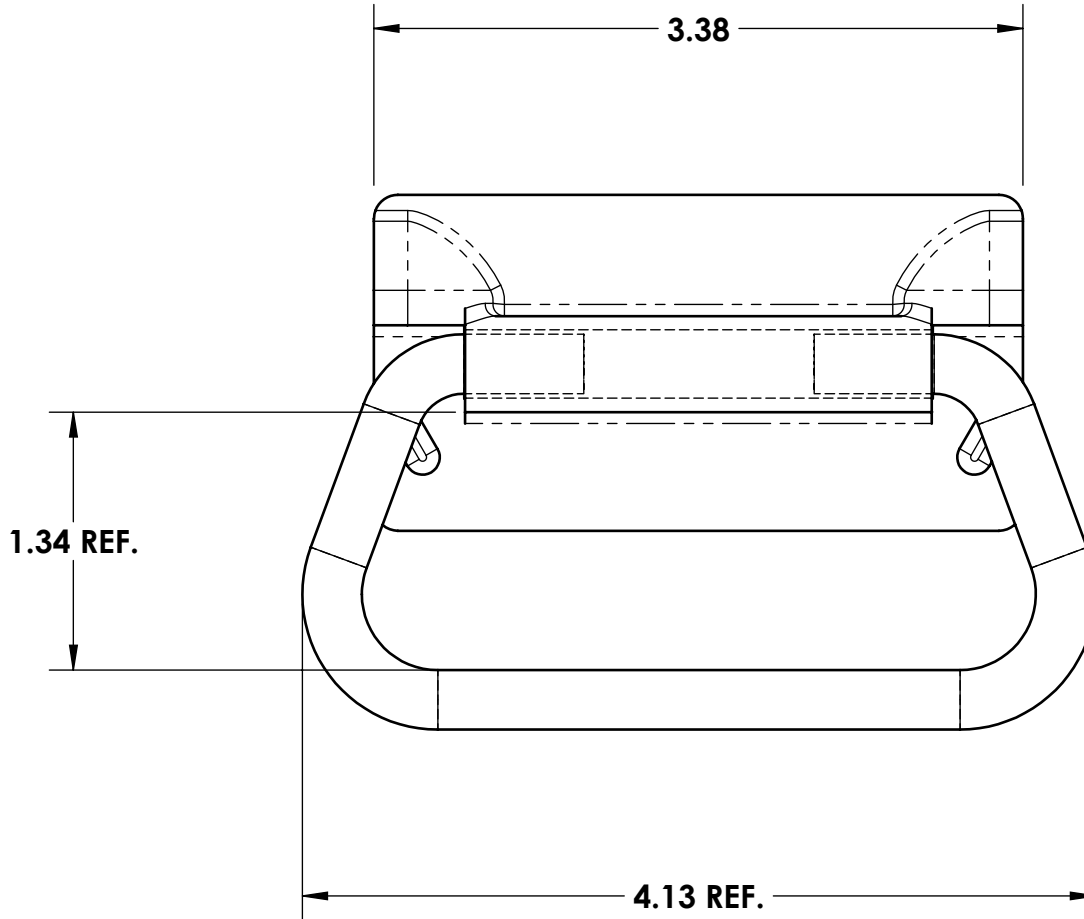

NOTES:
1. FINISH: 00- NO FINISH

REV.	DESCRIPTION	DATE	APPD
I	CONVERTED	02/02/2018	JG
H	1.34 WAS 1.25, 1.79 WAS 1.75	06/28/2010	JG
G	ADDED BOSS	05/18/2010	JG
REVISIONS			

DWG #: NHPS1207	
MATERIAL: PS	FINISH: SEE NOTE
DR. BY: RAG	CK. BY: CD
FAX: 1-631-737-2933 EMAIL: info@guden.com WEB: www.guden.com	

SCALE	1:1	CODE IDENT. #
DATE	06/01/1999	03007
99 RAYNOR AVE. RONKONKOMA, N.Y. 11779 1-800-3-HINGES		