

**B
SIZE**

PROJECTIONS

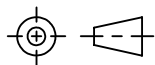

TOLERANCES UNLESS OTHERWISE SPECIFIED:

PLACES	INCHES	NOTES:
.XX	± .030	ACCEPTABLE BURR ± 10% OF MATERIAL THICKNESS
.XXX	± .015	ALL TOLERANCES ARE NON-CUMULATIVE
.XXXX	± .005	ALL DIMENSIONS APPLY TO PART BEFORE ANY
ANGLE	± 3°	FINISH IS APPLIED

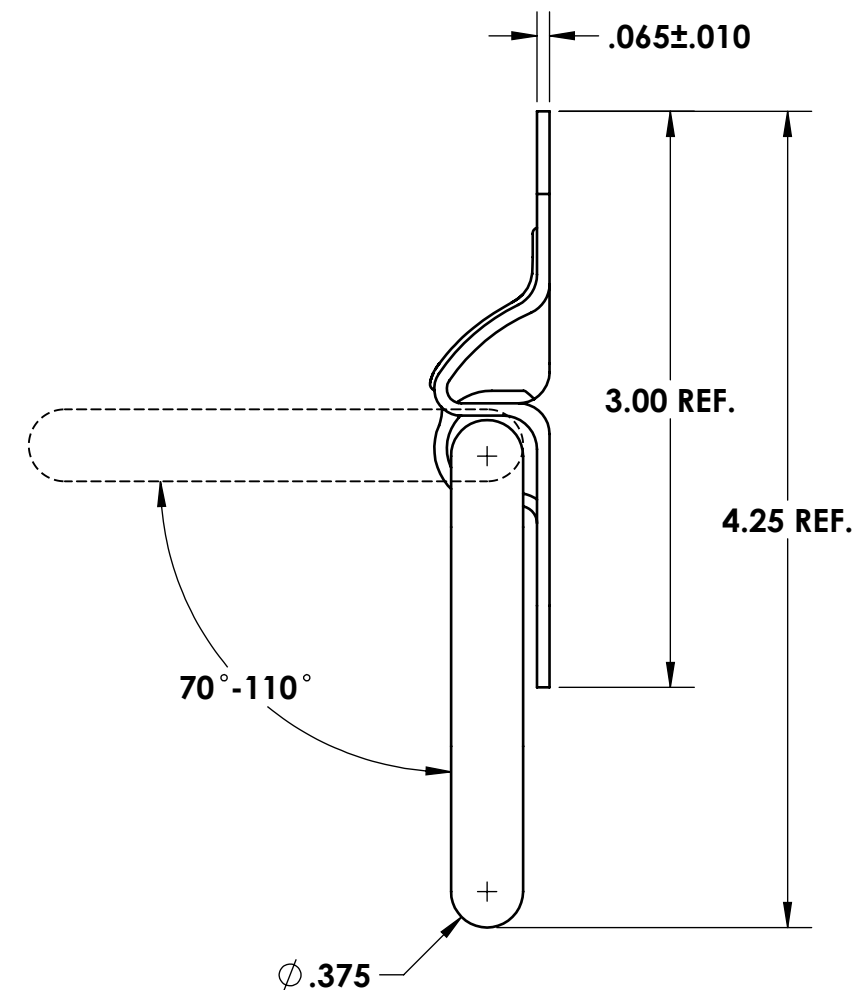
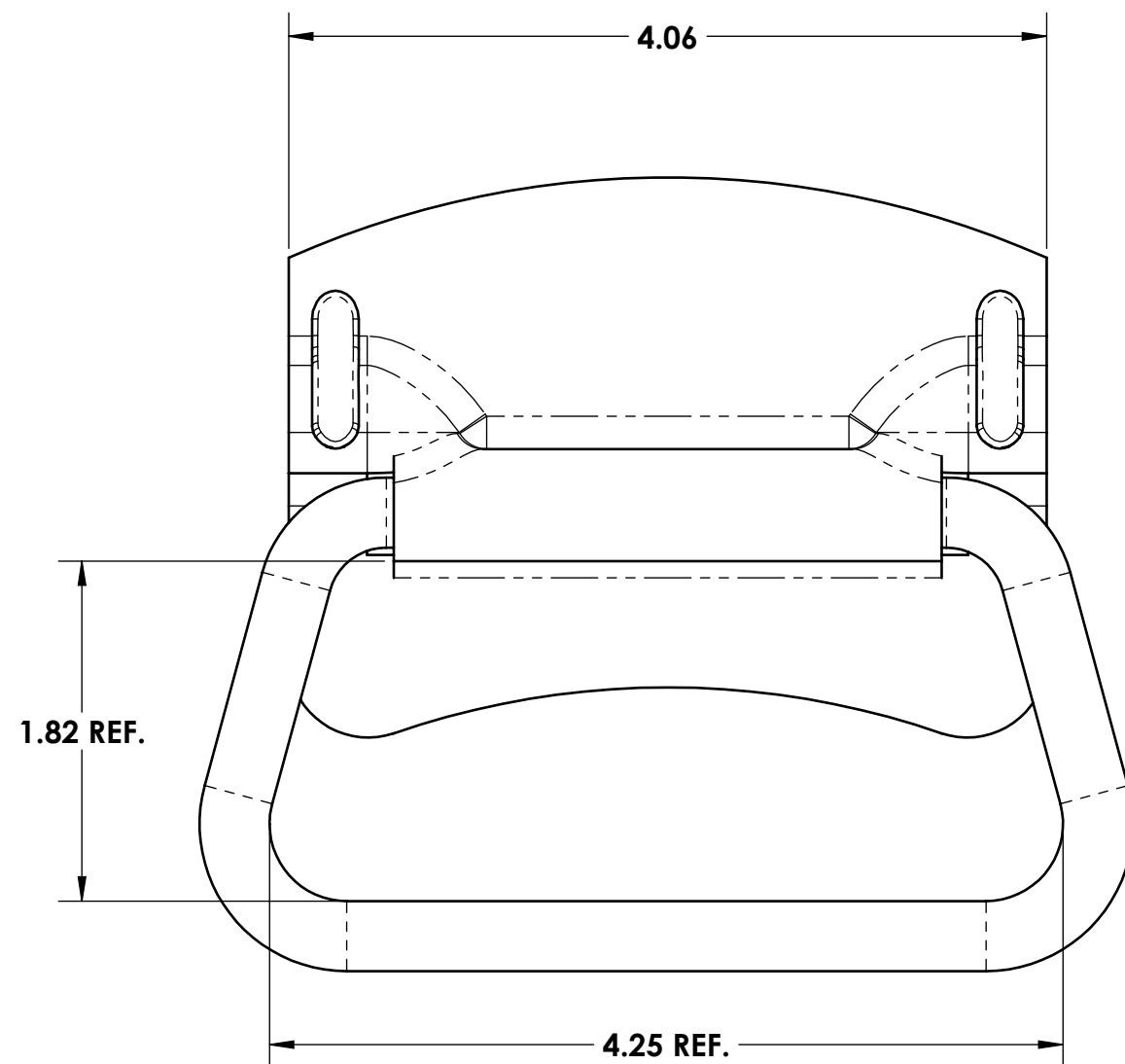

NOTES:
1. FINISH: 00- NO FINISH

REV.	DESCRIPTION	DATE	APPD
C	CONVERTED	08/25/2017	JG
B	REDRAWN	06/01/1999	CD
A	REDRAWN	02/03/1992	CD
REV.	DESCRIPTION	DATE	APPD
REVISIONS			

DWG #:	NHPS1205-400		SCALE	1:1	CODE IDENT. #
MATERIAL:	PS	FINISH:	SEE NOTE		
DR. BY:	RAG	CK. BY:	CD		
FAX: 1-631-737-2933			 GUDEN INDUSTRIAL HARDWARE MADE EASY 99 RAYNOR AVE. RONKONKOMA, N.Y. 11779 1-800-3-HINGES		
EMAIL: info@guden.com					
WEB: www.guden.com					
DATE		06/01/1999	03007		