

A
SIZE

PROJECTIONS

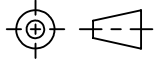

| COMPONENT | MATERIAL | FINISH |
|-----------|----------|------------------|
| BACKPLATE | ALUM | 07- CAUSTIC ETCH |
| BAIL | STS | 26- PASSIVATE |
| SPRING | STS | 26- PASSIVATE |
| GRIP | RUBBER | 00- NO FINISH |

TOLERANCES UNLESS OTHERWISE SPECIFIED:

| PLACES | INCHES | NOTES: |
|--------|--------|---|
| .XX | ± .030 | ACCEPTABLE BURR ± 10% OF MATERIAL THICKNESS |
| .XXX | ± .015 | ALL TOLERANCES ARE NON-CUMULATIVE |
| .XXXX | ± .005 | ALL DIMENSIONS APPLY TO PART BEFORE ANY FINISH IS APPLIED |
| ANGLE | ± 3° | |

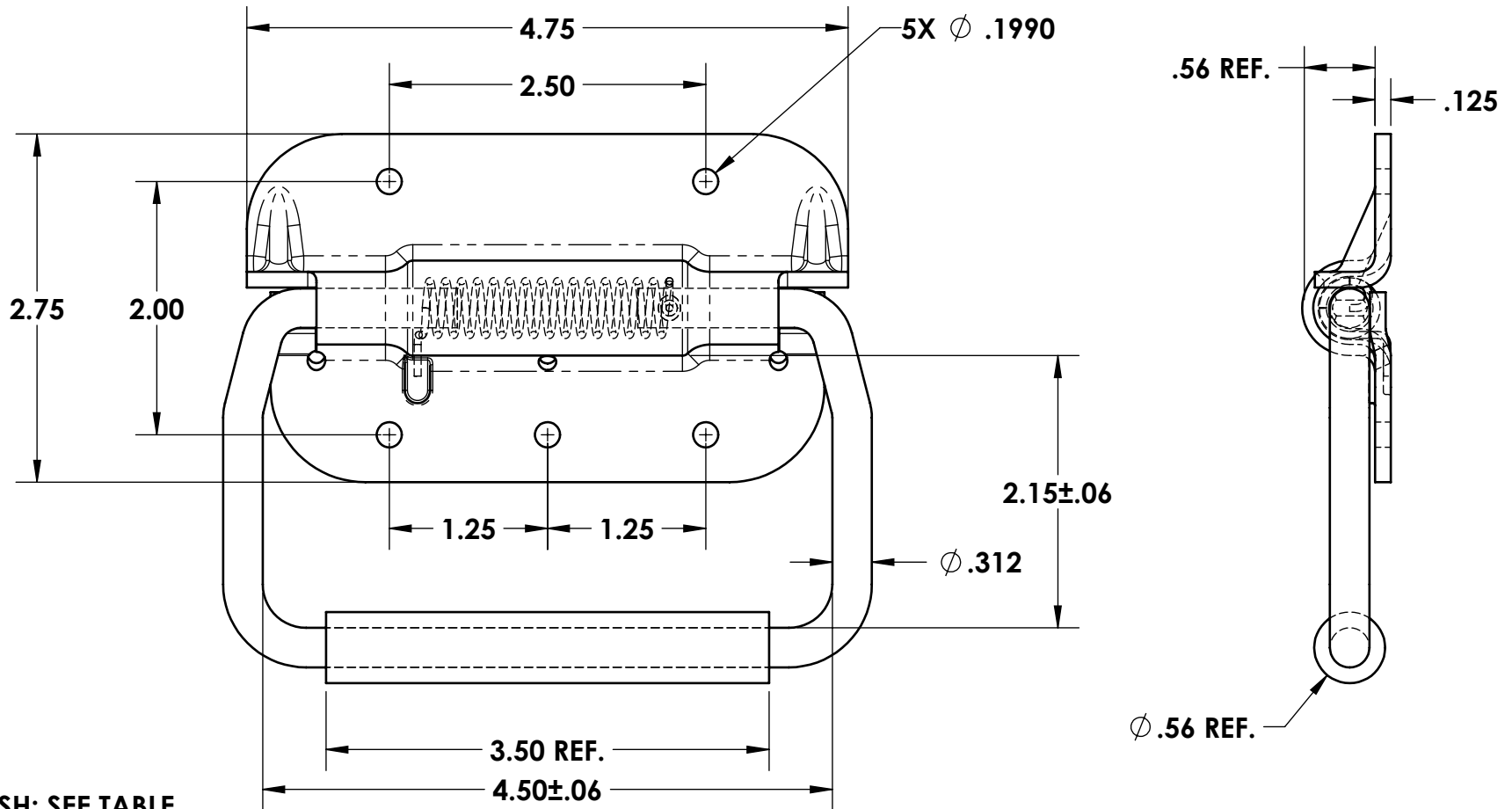

- NOTES:
 1. FINISH: SEE TABLE
 2. MATERIAL: SEE TABLE

| REV. | DESCRIPTION | DATE | APPD |
|-----------|---------------------------|------------|------|
| C | CONVERTED | 02/21/2018 | JG |
| B | 3.50 REF WAS 3.50 +- .060 | 01/06/2015 | JG |
| A | VARIOU CHANGES | 09/22/2014 | JG |
| REVISIONS | | | |

| | | | | |
|--|--|---------------------|------------|---------------|
| DWG #: | | SCALE | 3:4 | CODE IDENT. # |
| HA945SS2RG | | DATE | 04/27/1999 | 03007 |
| MATERIAL: SEE NOTE | | FINISH: SEE NOTE | | |
| DR. BY: RAG | | CK. BY: CD | | |
| FAX: 1-631-737-2933 EMAIL: info@guden.com WEB: www.guden.com | | | | |

| |
|--|
| GUDEN |
| INDUSTRIAL HARDWARE MADE EASY |
| 99 RAYNOR AVE. RONKONKOMA, N.Y. 11779 1-800-3-HINGES |