

**A**  
SIZE

PROJECTIONS

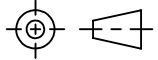

COMPONENT	MATERIAL	FINISH
BACKPLATE	ALUM	07- CAUSTIC ETCH
BAIL	STS	26- PASSIVATE
SPRING	STS	26- PASSIVATE
GRIP	RUBBER	00- NO FINISH

TOLERANCES UNLESS OTHERWISE SPECIFIED:

PLACES	INCHES	NOTES:
.XX	± .030	ACCEPTABLE BURR ± 10% OF MATERIAL THICKNESS
.XXX	± .015	ALL TOLERANCES ARE NON-CUMULATIVE
.XXXX	± .005	ALL DIMENSIONS APPLY TO PART BEFORE ANY FINISH IS APPLIED
ANGLE	± 3°	

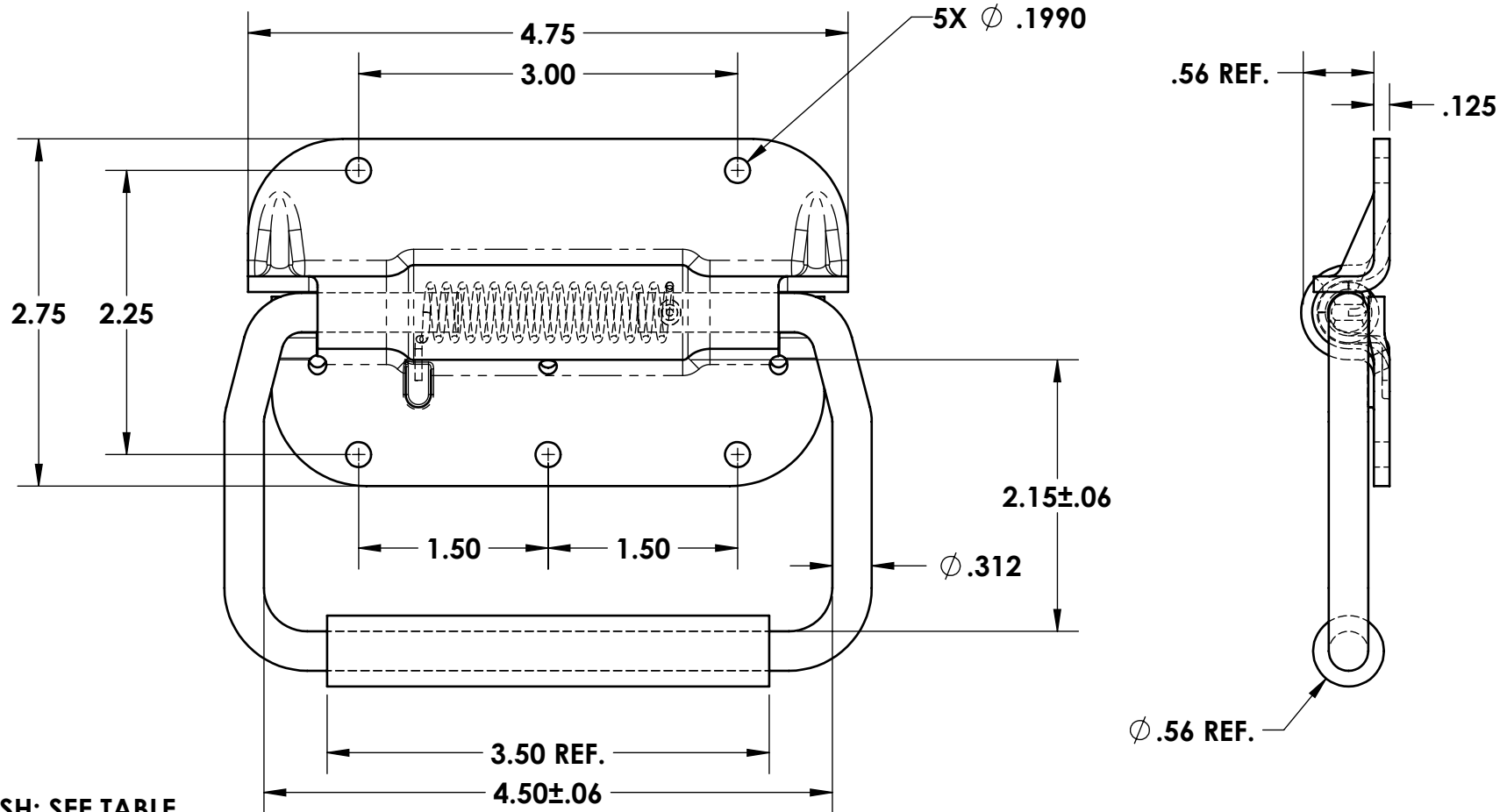

- NOTES:  
 1. FINISH: SEE TABLE  
 2. MATERIAL: SEE TABLE

DWG #:		SCALE	3:4	CODE IDENT. #
<b>H945SS2RG</b>		DATE	09/22/2014	03007
MATERIAL:	FINISH:	 <b>GUDEN</b> INDUSTRIAL HARDWARE MADE EASY 99 RAYNOR AVE. RONKONKOMA, N.Y. 11779 1-800-3-HINGES		
SEE NOTE	SEE NOTE			
DR. BY: RAG	CK. BY: JPG			
FAX: 1-631-737-2933 EMAIL: info@guden.com WEB: www.guden.com				

REV.	DESCRIPTION	DATE	APPD
B	CONVERTED	02/21/2018	JG
A	3.50 REF WAS 3.50 +- .060	01/06/2015	JG
REVISIONS			