

A
SIZE

PROJECTIONS

COMPONENT	MATERIAL	FINISH
BACKPLATE	ALUM	07- CAUSTIC ETCH
BAIL	ALUM	07- CAUSTIC ETCH
SPRING	STS	26- PASSIVATE
GRIP	RUBBER	00- NO FINISH

TOLERANCES UNLESS OTHERWISE SPECIFIED:

PLACES	INCHES	NOTES:
.XX	± .030	ACCEPTABLE BURR ± 10% OF MATERIAL THICKNESS
.XXX	± .015	ALL TOLERANCES ARE NON-CUMULATIVE
.XXXX	± .005	ALL DIMENSIONS APPLY TO PART BEFORE ANY FINISH IS APPLIED
ANGLE	± 3°	

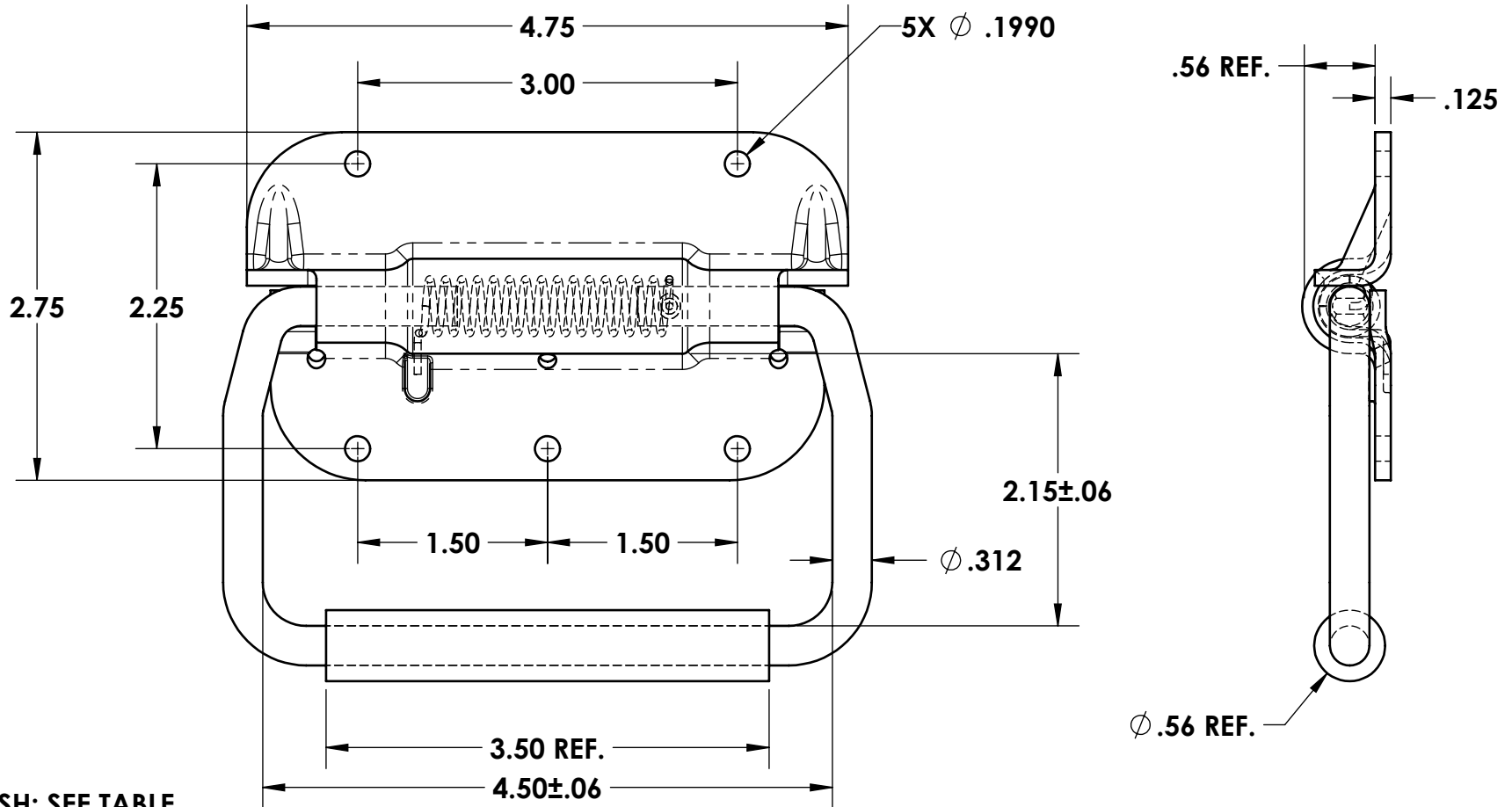

- NOTES:
 1. FINISH: SEE TABLE
 2. MATERIAL: SEE TABLE

REV.	DESCRIPTION	DATE	APPD
C	CONVERTED	02/21/2018	JG
B	3.50 REF WAS 3.50 +- .060	01/06/2015	JG
A	VARIOU CHANGES	09/22/2014	JG
REVISIONS			

DWG #:
H945AL2RG

MATERIAL: SEE NOTE FINISH: SEE NOTE

DR. BY: RAG CK. BY: CD

FAX: 1-631-737-2933
 EMAIL: info@guden.com
 WEB: www.guden.com

SCALE	3:4	CODE IDENT. #
DATE	12/29/2004	03007
 GUDEN INDUSTRIAL HARDWARE MADE EASY 99 RAYNOR AVE. RONKONKOMA, N.Y. 11779 1-800-3-HINGES		