

B
SIZE

PROJECTIONS

TOLERANCES UNLESS OTHERWISE SPECIFIED:		
PLACES	INCHES	NOTES:
.XX	± .030	ACCEPTABLE BURR ± 10% OF MATERIAL THICKNESS
.XXX	± .015	ALL TOLERANCES ARE NON-CUMULATIVE
.XXXX	± .005	ALL DIMENSIONS APPLY TO PART BEFORE ANY FINISH IS APPLIED
ANGLE	± 3°	

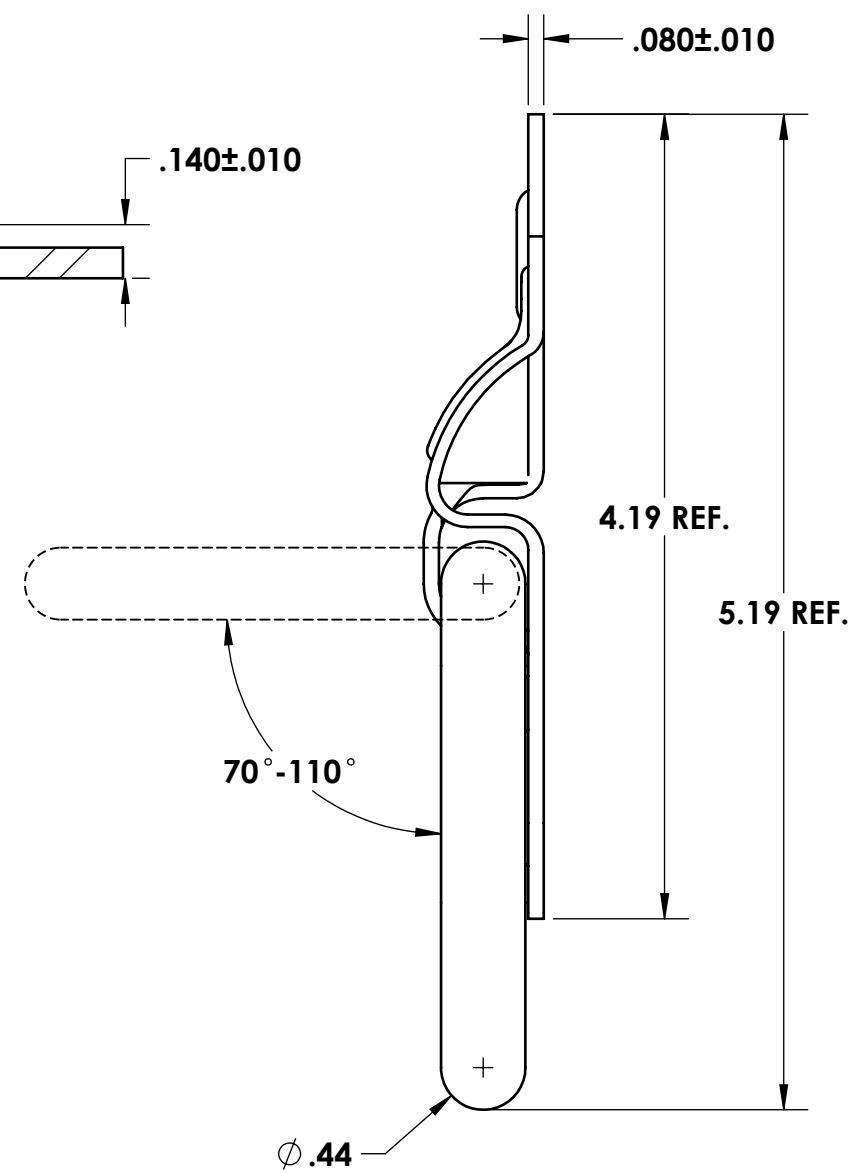
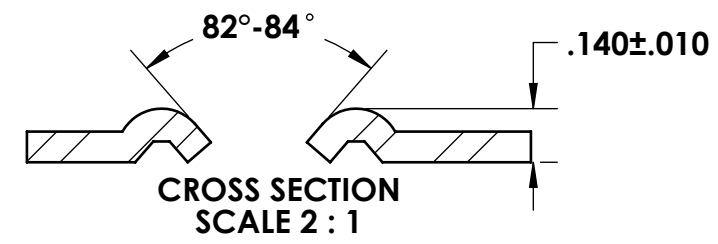
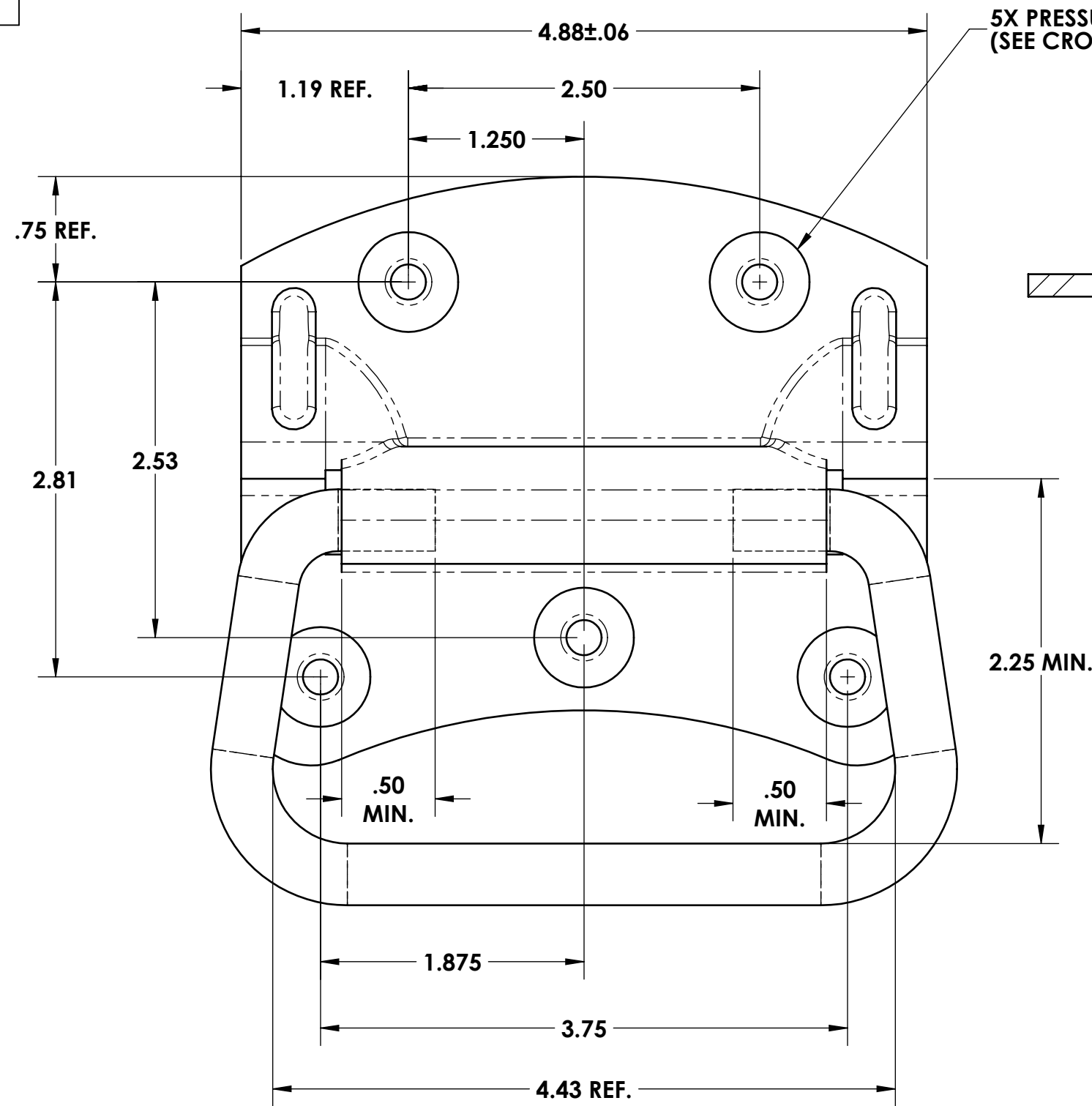

NOTES:
 1. FINISH: 105- BARREL ZINC AND CLEAR TRIVALENT CHROMATE
 2. HANDLE PACKAGED IN PLASTIC BAG WITH (5) #12 X 1" FHWS (PHILLIPS)

REV.	DESCRIPTION	DATE	APPD
F	CONVERTED	02/01/2018	JG
E	REDRAWN, VARIOUS CHANGES	02/24/2015	JG
D	REDRAWN, VARIOUS CHANGES	10/14/2002	CD
C	REDRAWN	02/12/1992	AG
REVISIONS			

DWG #:	1205-475-02		SCALE	1:1	CODE IDENT. #
MATERIAL:	PS	FINISH:	SEE NOTE		
DR. BY:	RAG	CK. BY:	CD		
FAX: 1-631-737-2933			 INDUSTRIAL HARDWARE MADE EASY 99 RAYNOR AVE. RONKONKOMA, N.Y. 11779 1-800-3-HINGES		
EMAIL: info@guden.com					
WEB: www.guden.com					
DATE		12/21/1987	03007		