

A
SIZE

PROJECTIONS

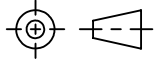

TOLERANCES UNLESS OTHERWISE SPECIFIED:

PLACES	INCHES	NOTES:
.XX	± .030	ACCEPTABLE BURR ± 10% OF MATERIAL THICKNESS
.XXX	± .015	ALL TOLERANCES ARE NON-CUMULATIVE
.XXXX	± .005	ALL DIMENSIONS APPLY TO PART BEFORE ANY FINISH IS APPLIED
ANGLE	± 3°	

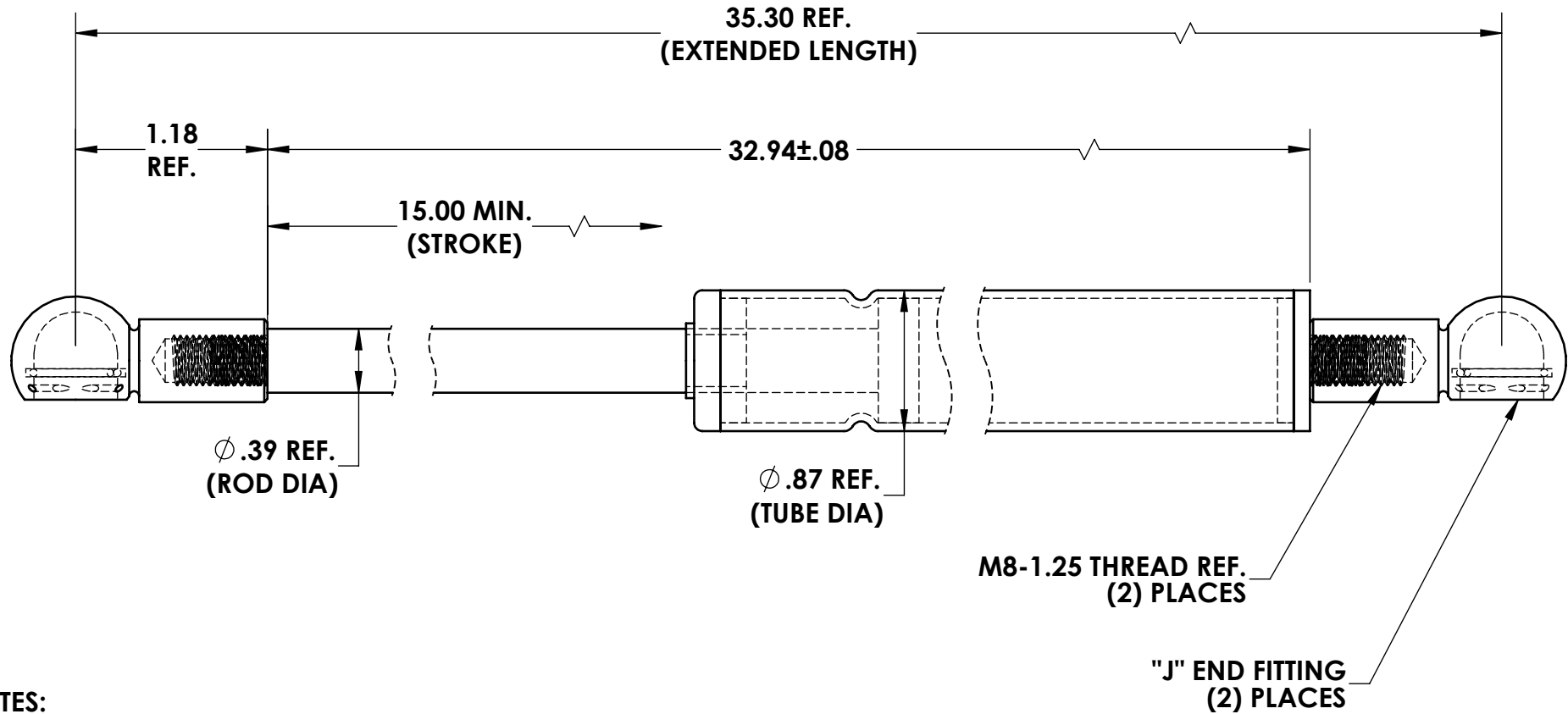

NOTES:

1. FINISH: 00- NO FINISH
2. MATERIAL: TUBE = 316L-ST
ROD = 303-ST
3. PART MARK WITH GUDEN P/N AND DATE CODE
4. P1 FORCE = 150 LBS ± 10 LBS

DWG #:

STS38-150-J

SCALE

1:1

CODE IDENT. #

DATE

12/02/2015

03007

MATERIAL:
SEE NOTEFINISH:
SEE NOTE

DR. BY: RAG

CK. BY: JPG

FAX: 1-631-737-2933

EMAIL: info@guden.com

WEB: www.guden.com

GUDEN

INDUSTRIAL HARDWARE MADE EASY

99 RAYNOR AVE.

RONKONKOMA, N.Y. 11779

1-800-3-HINGES

A	P1 TOLERANCE	09/20/2017	JG
REV.	DESCRIPTION	DATE	APPD
REVISIONS			