

A
SIZE

PROJECTIONS



TOLERANCES UNLESS OTHERWISE SPECIFIED:

PLACES	INCHES	NOTES:
.XX	± .030	ACCEPTABLE BURR ± 10% OF MATERIAL THICKNESS
.XXX	± .015	ALL TOLERANCES ARE NON-CUMULATIVE
.XXXX	± .005	ALL DIMENSIONS APPLY TO PART BEFORE ANY FINISH IS APPLIED
ANGLE	± 3°	

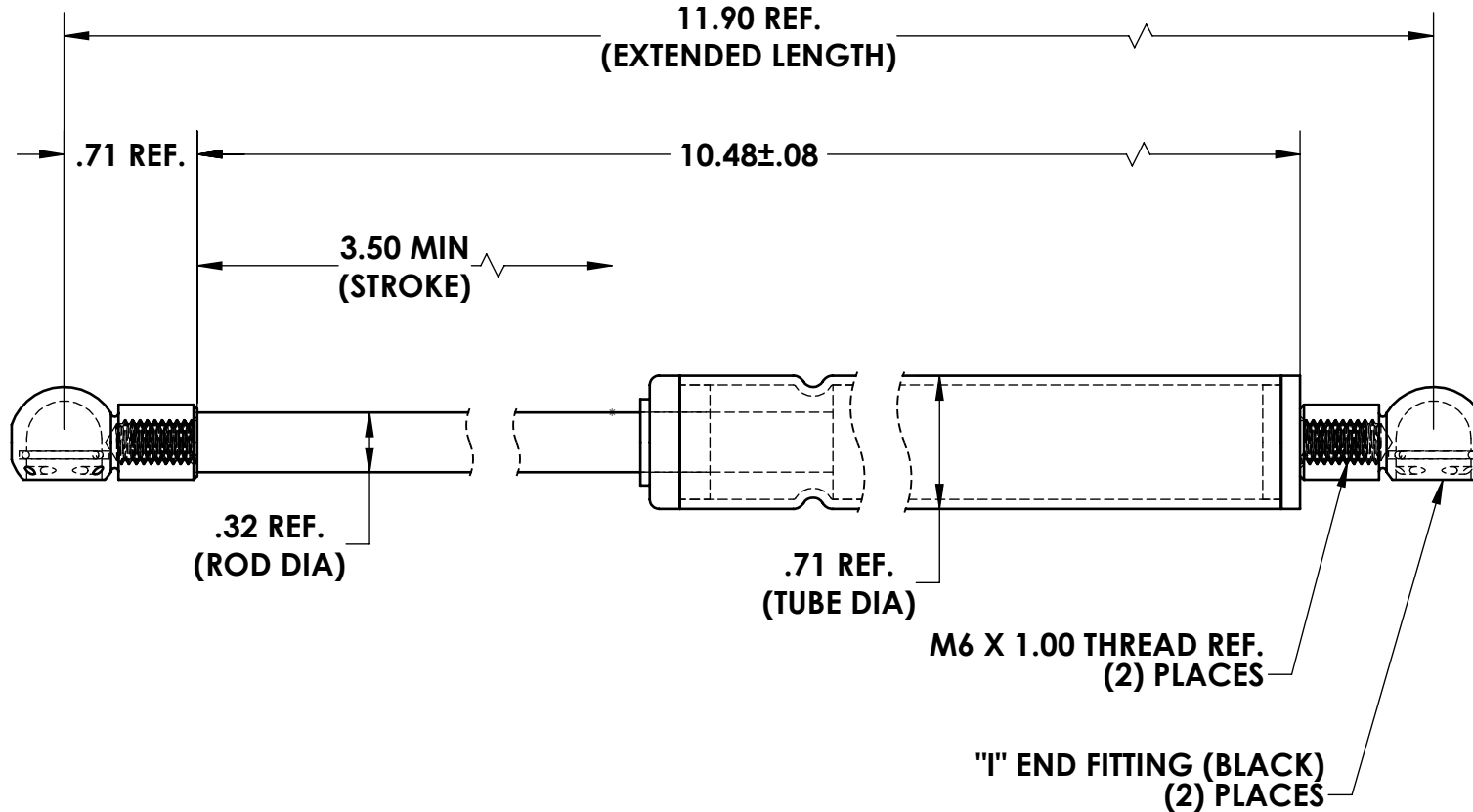

NOTES:

1. FINISH: 51A BLACK PAINT (TUBE) AND BLACK NITRIDE (ROD)
2. PART MARK WITH GUDEN P/N AND DATE CODE
3. P1 FORCE = 90 lbs. ± 7.0 lbs.

REV. DESCRIPTION DATE APPD				DWG #:	SCALE	1:1	CODE IDENT. #
C	CONVERTED	03/22/2017	JG	GGN21-090-1	DATE	06/13/2005	03007
B	VARIOUS CHANGES	07/08/2015	JG		MATERIAL: PS	FINISH: SEE NOTE	
A	VARIOUS CHANGES	01/19/2015	JG	DR. BY: RAG	CK. BY: CD		<p>GUDEN INDUSTRIAL HARDWARE MADE EASY 99 RAYNOR AVE. RONKONKOMA, N.Y. 11779 1-800-3-HINGES</p>
REV.	DESCRIPTION	DATE	APPD	FAX: 1-631-737-2933			
REVISIONS				EMAIL: info@guden.com			
				WEB: www.guden.com			