

A
SIZE

PROJECTIONS

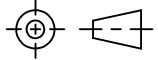

TOLERANCES UNLESS OTHERWISE SPECIFIED:

PLACES	INCHES	NOTES:
.XX	± .030	ACCEPTABLE BURR ± 10% OF MATERIAL THICKNESS
.XXX	± .015	ALL TOLERANCES ARE NON-CUMULATIVE
.XXXX	± .005	ALL DIMENSIONS APPLY TO PART BEFORE ANY FINISH IS APPLIED
ANGLE	± 3°	

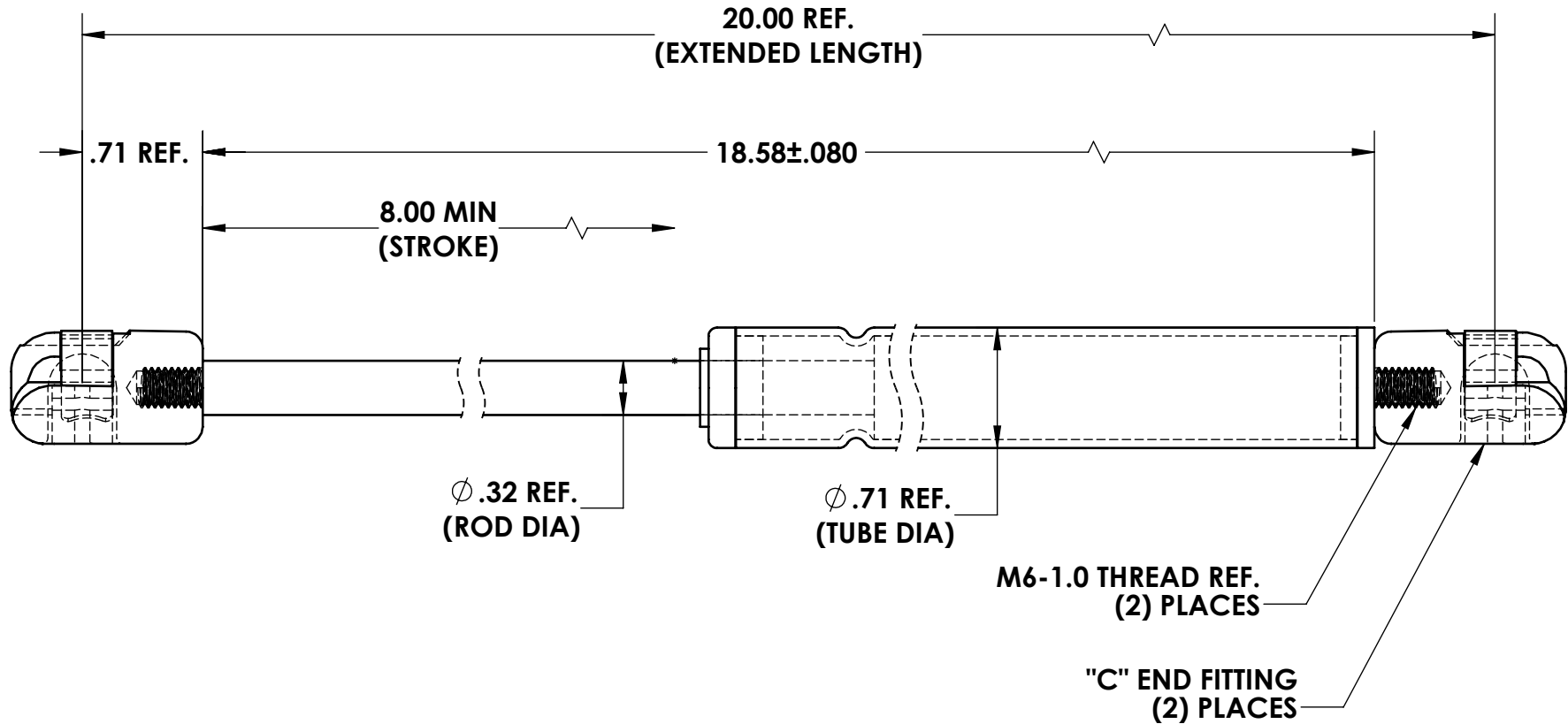

NOTES:

1. FINISH: 51A BLACK PAINT (TUBE) AND BLACK NITRIDE (ROD)
2. PART MARK WITH GUDEN P/N AND DATE CODE
3. P1 FORCE = 150 LBS ± 10.0 LBS

DWG #:		SCALE	1:1	CODE IDENT. #
GGN201-150-C		DATE	06/24/2016	03007
MATERIAL:	FINISH:	 GUDEN INDUSTRIAL HARDWARE MADE EASY 99 RAYNOR AVE. RONKONKOMA, N.Y. 11779 1-800-3-HINGES		
PS	SEE NOTE			
DR. BY: RAG	CK. BY: JPG			
FAX: 1-631-737-2933 EMAIL: info@guden.com WEB: www.guden.com				

REV.	DESCRIPTION	DATE	APPD
A	150 ± 10 WAS 150 ± 7	06/14/2018	JG
REVISIONS			