

A
SIZE

PROJECTIONS

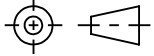

TOLERANCES UNLESS OTHERWISE SPECIFIED:

PLACES	INCHES	NOTES:
.XX	± .030	ACCEPTABLE BURR ± 10% OF MATERIAL THICKNESS
.XXX	± .015	ALL TOLERANCES ARE NON-CUMULATIVE
.XXXX	± .005	ALL DIMENSIONS APPLY TO PART BEFORE ANY
ANGLE	± 3°	FINISH IS APPLIED

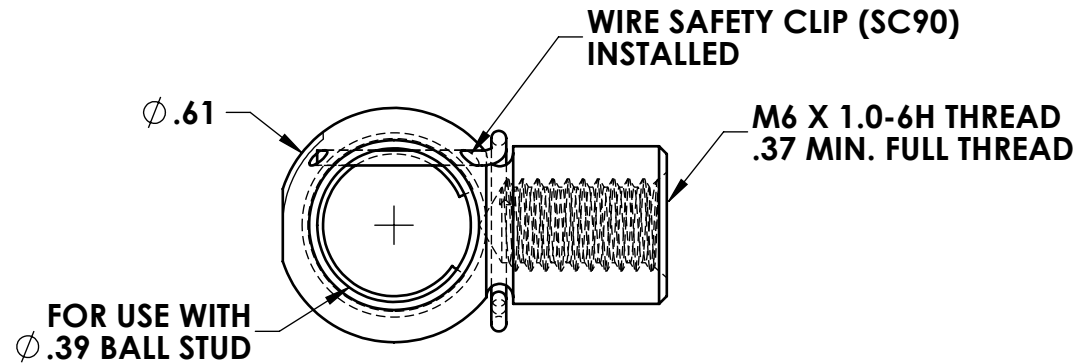
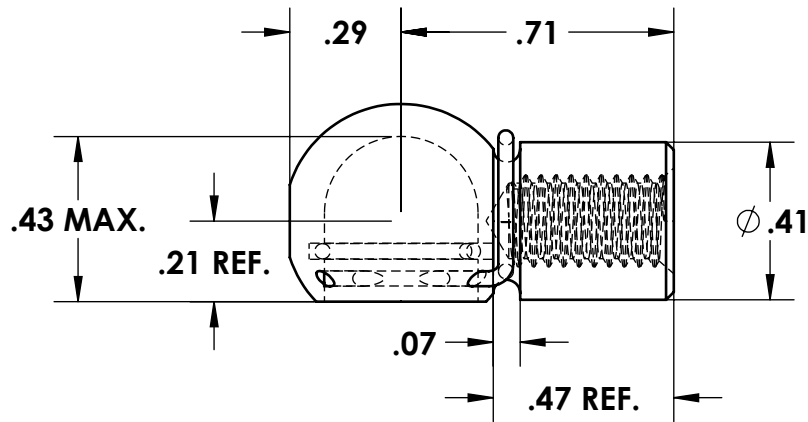

NOTES:

1. FINISH: 105- BARREL ZINC & CLEAR TRIVALENT CHROMATE

REV.	DESCRIPTION	DATE	APPD	DWG #:	SCALE	2:1	CODE IDENT. #
D	SC90 INSTALLED	03/26/2024	JG	EF090A-02	DATE	11/29/2004	03007
C	VARIOUS CHANGES	03/31/2021	JG		MATERIAL:	PS	FINISH:
B	.37 MIN. WAS .43 MIN.	06/05/2018	JG	DR. BY:	RAG	CK. BY:	CD
A	CONVERTED	03/16/2017	JG	FAX: 1-631-737-2933		 99 RAYNOR AVE. RONKONKOMA, N.Y. 11779 1-800-3-HINGES	
REV.	DESCRIPTION	DATE	APPD	EMAIL: info@guden.com			
REVISIONS				WEB: www.guden.com			