

A
SIZE

PROJECTIONS

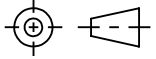

TOLERANCES UNLESS OTHERWISE SPECIFIED:

PLACES	INCHES	NOTES:
.XX	± .030	ACCEPTABLE BURR ± 10% OF MATERIAL THICKNESS
.XXX	± .015	ALL TOLERANCES ARE NON-CUMULATIVE
.XXXX	± .005	ALL DIMENSIONS APPLY TO PART BEFORE ANY FINISH IS APPLIED
ANGLE	± 3°	

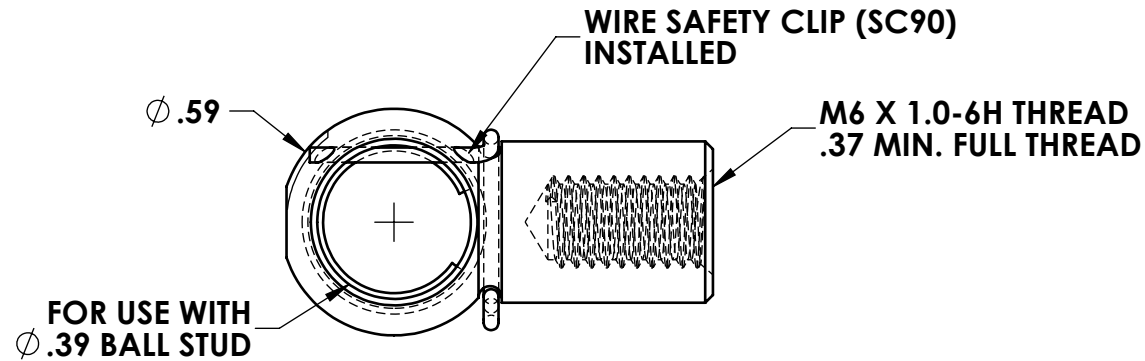
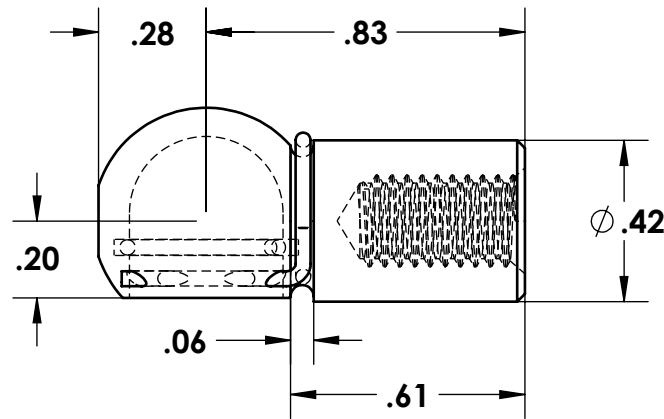

NOTES:
1. FINISH: 105- BARREL ZINC & CLEAR TRIVALENT CHROMATE

REV.	DESCRIPTION	DATE	APPD	DWG #:	SCALE	2:1	CODE IDENT. #	
G	ADDED SC90 INSTALLED	09/16/2022	JG	EF090-02	DATE	07/27/1989	03007	
F	.37 MIN. WAS .43 MIN.	06/05/2018	JG		<div style="text-align: center;"> <h1 style="margin: 0;">GUDEN</h1> <p style="margin: 0;">INDUSTRIAL HARDWARE MADE EASY</p> <p style="margin: 0;">99 RAYNOR AVE.</p> <p style="margin: 0;">RONKONKOMA, N.Y. 11779</p> <p style="margin: 0;">1-800-3-HINGES</p> </div>			
E	CONVERTED	03/17/2017	JG	MATERIAL: PS				FINISH: SEE NOTE
D	REDRAWN, .61 WAS .74	07/23/1998	CD	DR. BY: RAG				CK. BY: JPG
REVISIONS				FAX: 1-631-737-2933 EMAIL: info@guden.com WEB: www.guden.com				