

B
SIZE

PROJECTIONS

TOLERANCES UNLESS OTHERWISE SPECIFIED:

PLACES	INCH	NOTE:
.XX	± .030	ACCEPTABLE BURR ± 10% OF MATERIAL THICKNESS ALL TOLERANCES ARE NON-CUMULATIVE ALL DIMENSIONS APPLY TO PART BEFORE ANY FINISH IS APPLIED
.XXX	± .015	
.XXXX	± .005	
ANGLE	± 3°	

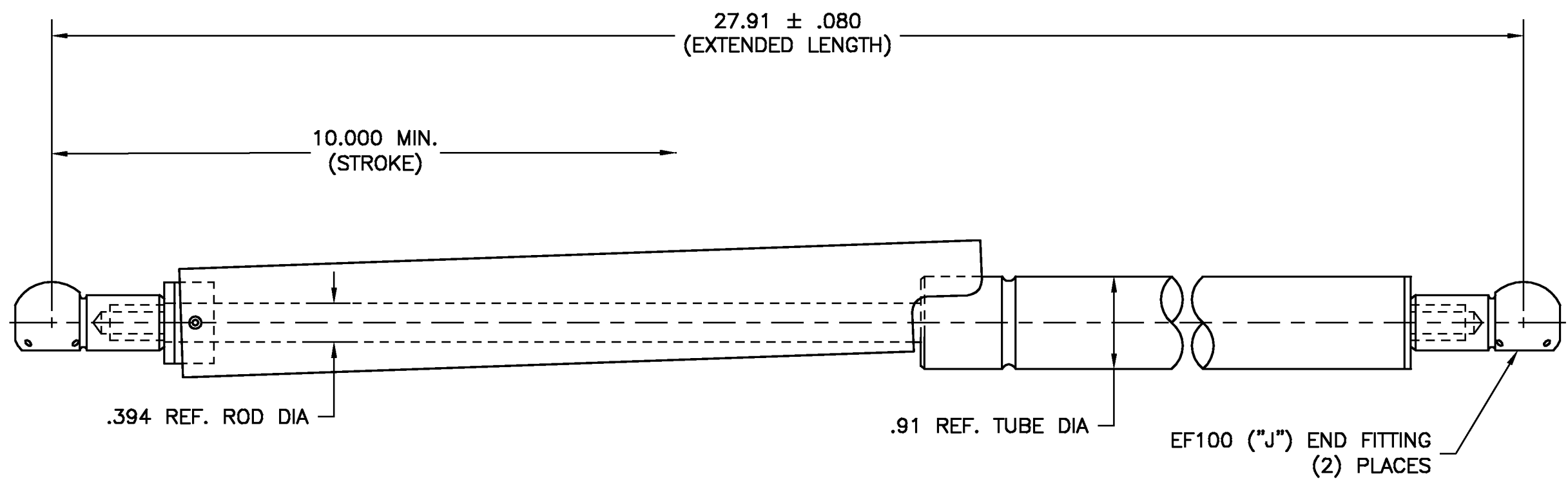

- NOTES:
1. FINISH: 51- BLACK PAINT (TUBE) AND BLACK NITROTEC (ROD)
 2. LABEL TO BE STAMPED WITH CORRESPONDING GUDEN P/N AND DATE CODE. (DATE CODE EX.: 09/04 IS THE 9th MONTH OF 2004)
 3. P1 FORCE = 200 lbs ± 10.0 lbs

C	DESCRIPTION	DATE	APPD
C	VARIOUS CHANGES	05/18/16	JG
B	REMOVED PLASTIC CAP	01/17/12	JG
A	CHANGED LOCK TUBE	09/29/04	CD
LTR	DESCRIPTION	DATE	APPD
REVISION			

DWG	SCALE	N/A	CODE IDENT. #
ECL31-200-J	DATE	05/11/04	03007
MATERIAL	FINISH		
PS	SEE NOTE		
DR. BY RAG	CK. BY CD	99 RAYNOR AVE. RONKONKOMA, N.Y. 11779 1-800-3-HINGES	
FAX: 1-631-737-2933 EMAIL: info@guden.com WEB: www.guden.com			