

A
SIZE

PROJECTIONS

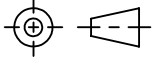

TOLERANCES UNLESS OTHERWISE SPECIFIED:

PLACES	INCHES	NOTES:
.XX	± .030	ACCEPTABLE BURR ± 10% OF MATERIAL THICKNESS
.XXX	± .015	ALL TOLERANCES ARE NON-CUMULATIVE
.XXXX	± .005	ALL DIMENSIONS APPLY TO PART BEFORE ANY FINISH IS APPLIED
ANGLE	± 3°	

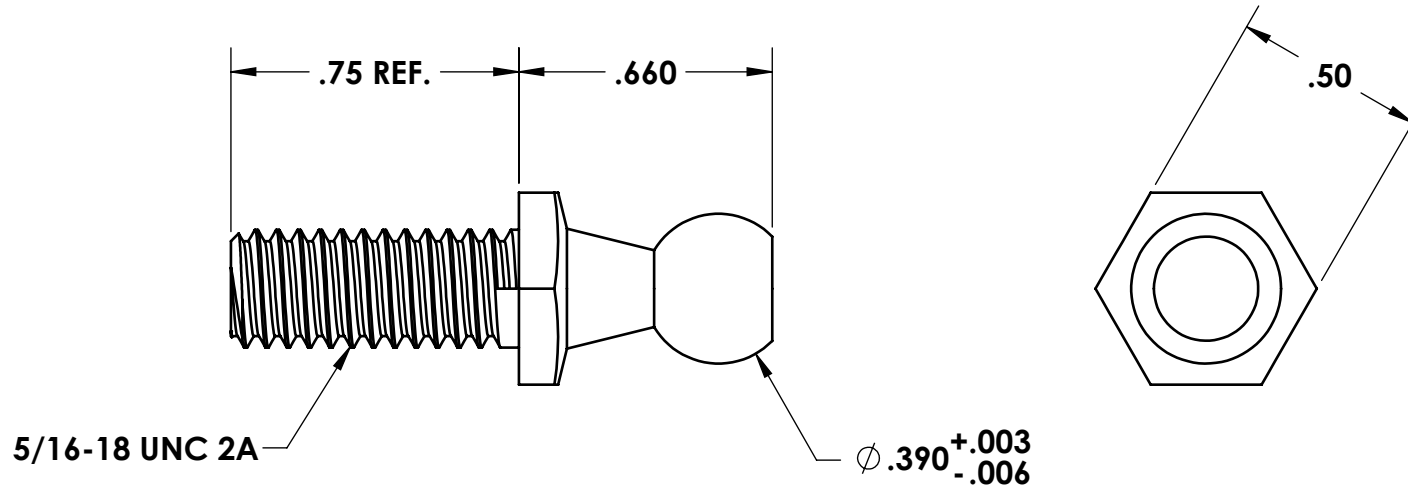

NOTES:

1. FINISH: 200- ZINC PER ASTM B633 SC1 TYPE I

REV. DESCRIPTION DATE APPD				DWG #:		SCALE	2:1	CODE IDENT. #
				BS104-02		DATE	08/24/2004	03007
C	VARIOUS CHANGES	02/23/2021	JG	MATERIAL:	FINISH:	 GUDEN INDUSTRIAL HARDWARE MADE EASY 99 RAYNOR AVE. RONKONKOMA, N.Y. 11779 1-800-3-HINGES		
B	VARIOUS CHANGES	01/04/2011	JG	PS	SEE NOTE			
A	CHANGED STUD LENGTH	11/09/2004	CD	DR. BY: RAG	CK. BY: CD			
REV.	DESCRIPTION	DATE	APPD	FAX: 1-631-737-2933 EMAIL: info@guden.com WEB: www.guden.com				
REVISIONS								