

A
SIZE

PROJECTIONS

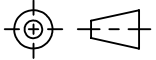

TOLERANCES UNLESS OTHERWISE SPECIFIED:

PLACES	INCHES	NOTES:
.XX	± .030	ACCEPTABLE BURR ± 10% OF MATERIAL THICKNESS
.XXX	± .015	ALL TOLERANCES ARE NON-CUMULATIVE
.XXXX	± .005	ALL DIMENSIONS APPLY TO PART BEFORE ANY FINISH IS APPLIED
ANGLE	± 3°	

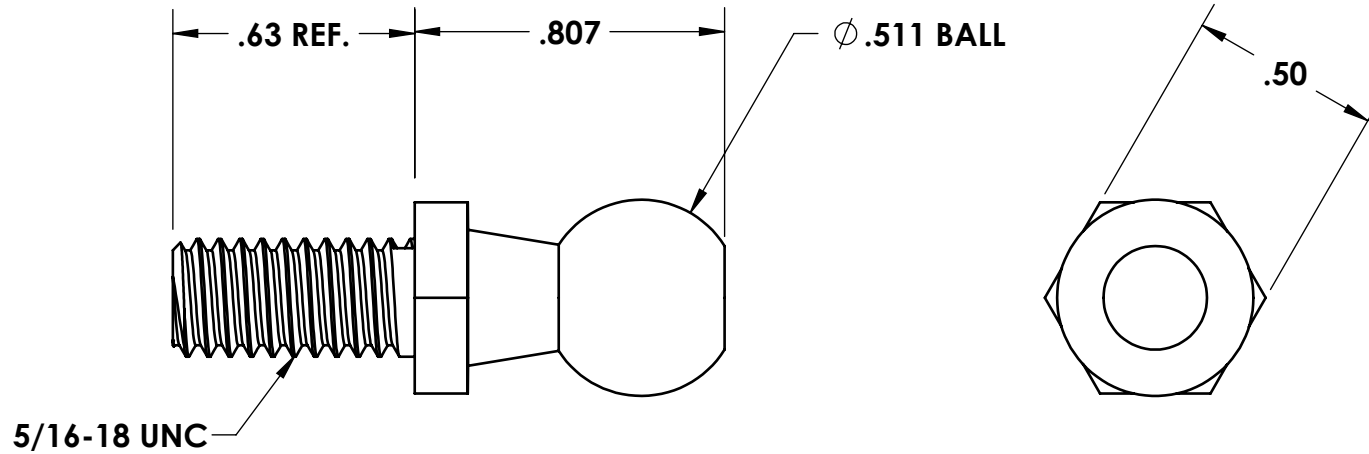

NOTES:

- FINISH: 00- NO FINISH

D	.807 WAS .810	06/25/2018	JG	DWG #: BS102-32	SCALE	2:1	CODE IDENT. #
C	CONVERTED, VARIOUS CHANGES	09/25/2017	JG		DATE	07/18/1996	03007
B	VARIOUS CHANGES	09/17/2010	JG	MATERIAL: 316-ST5	FINISH: SEE NOTE		
A	CHANGED ROCKWELL	05/21/2004	CD	DR. BY: RAG	CK. BY: CD		
REV.	DESCRIPTION	DATE	APPD	FAX: 1-631-737-2933			
REVISIONS				EMAIL: info@guden.com			
				WEB: www.guden.com			