

A
SIZE

PROJECTIONS

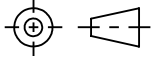

TOLERANCES UNLESS OTHERWISE SPECIFIED:

PLACES	INCHES	NOTES:
.XX	± .030	ACCEPTABLE BURR ± 10% OF MATERIAL THICKNESS
.XXX	± .015	ALL TOLERANCES ARE NON-CUMULATIVE
.XXXX	± .005	ALL DIMENSIONS APPLY TO PART BEFORE ANY FINISH IS APPLIED
ANGLE	± 3°	

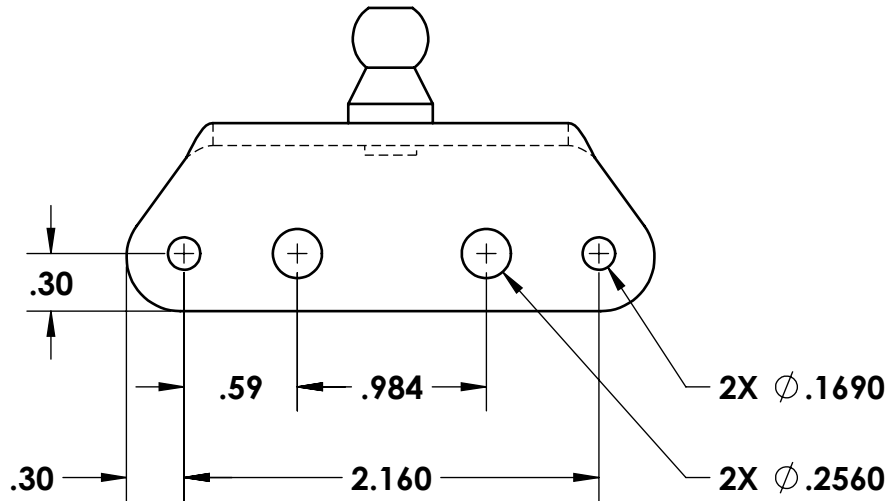
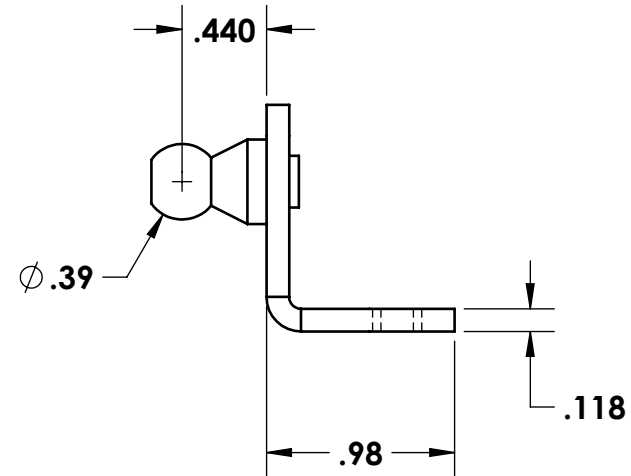
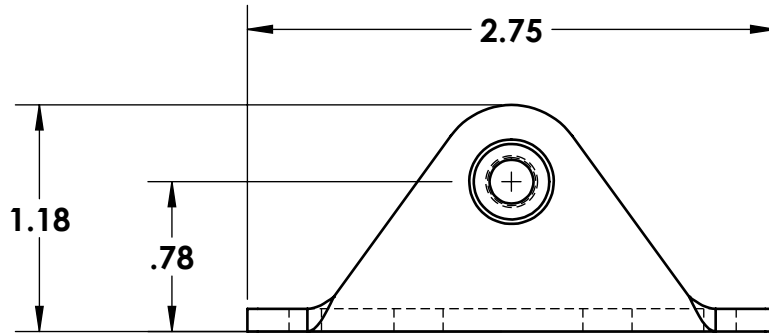

NOTES:
1. FINISH: 105- BARREL ZINC AND CLEAR TRIVALENT CHROMATE

REV.	DESCRIPTION	DATE	APPD
C	CONVERTED	01/26/2018	JG
B	CHANGED FINISH	05/06/2015	JG
A	CHANGED FINISH	02/01/2012	JG

REVISIONS

DWG #:

BR208-02

MATERIAL:
PS

FINISH:
SEE NOTE

DR. BY: RAG

CK. BY: CD

FAX: 1-631-737-2933
EMAIL: info@guden.com
WEB: www.guden.com

SCALE

1:1

CODE IDENT. #

DATE

05/09/2001

03007

GUDEN
INDUSTRIAL HARDWARE MADE EASY

99 RAYNOR AVE.
RONKONKOMA, N.Y. 11779
1-800-3-HINGES