

**A**  
SIZE

PROJECTIONS

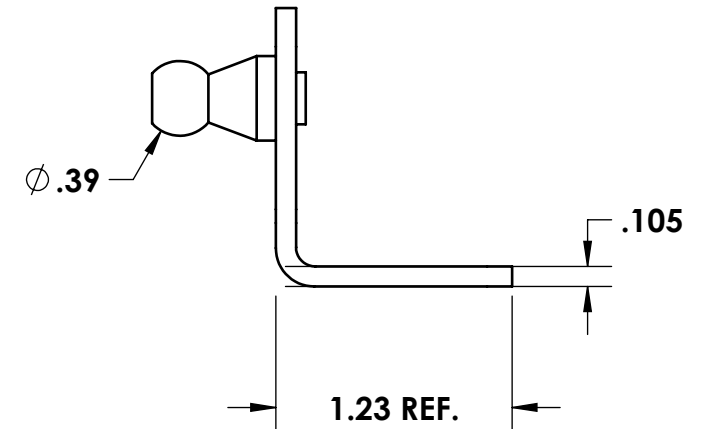
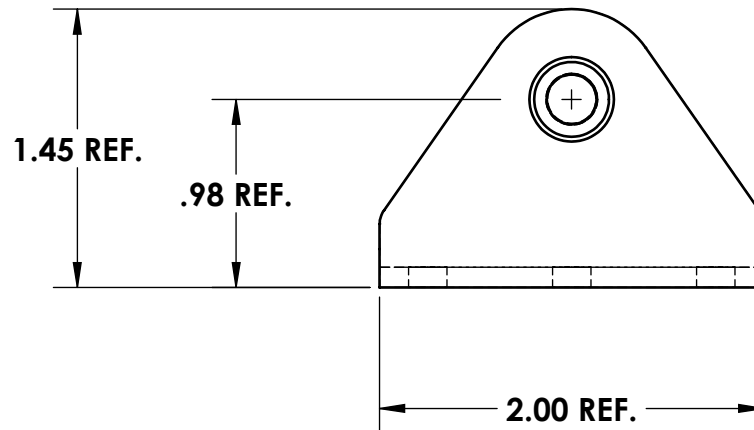
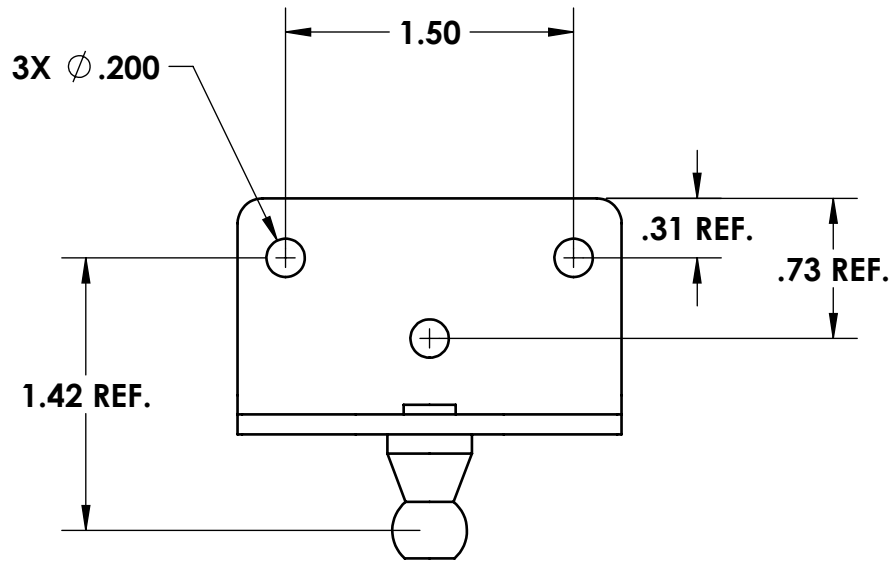
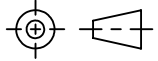

TOLERANCES UNLESS OTHERWISE SPECIFIED:

PLACES	INCHES	NOTES:
.XX	± .030	ACCEPTABLE BURR ± 10% OF MATERIAL THICKNESS
.XXX	± .015	ALL TOLERANCES ARE NON-CUMULATIVE
.XXXX	± .005	ALL DIMENSIONS APPLY TO PART BEFORE ANY FINISH IS APPLIED
ANGLE	± 3°	

## NOTES:

- FINISH: 00- NO FINISH

REV.	DESCRIPTION	DATE	APPD
F	CONVERTED, FINISH	06/09/2017	JG
E	CHANGED MATERIAL THICKNES	12/18/2006	CD
D	ADDED POLISH	02/05/2004	CD

REVISIONS

DWG #:

**BR205-32**MATERIAL:  
304-STSSFINISH:  
SEE NOTE

DR. BY: RAG

CK. BY: CD

FAX: 1-631-737-2933

EMAIL: info@guden.com

WEB: www.guden.com

SCALE

1:1

CODE IDENT. #

DATE

07/18/1996

03007

**GUDEN**

INDUSTRIAL HARDWARE MADE EASY

99 RAYNOR AVE.

RONKONKOMA, N.Y. 11779

1-800-3-HINGES